



Introduction to EEG, MEG and analysis with the FieldTrip toolbox

Robert Oostenveld

*Donders Institute, Radboud University, Nijmegen, NL
NatMEG, Karolinska Institute, Stockholm, SE*



What is FieldTrip

a MATLAB toolbox for the analysis of MEG, EEG
and animal electrophysiology data

can import data from many different file formats

contains algorithms for spectral analysis, source
reconstruction, statistics, connectivity, ...

Talk outline

What kind of signals are generated in the brain

How do we record those signals

Analyzing those signals with FieldTrip

Background on the FieldTrip toolbox

Talk outline

What kind of signals are generated in the brain

How do we record those signals

Analyzing those signals with FieldTrip

Background on the FieldTrip toolbox

What kind of signals are generated in the brain

We measure the scalp potentials or field associated with post-synaptic potentials in pyramidal neurons

These PSPs represent the excitatory and inhibitory input that these neurons receive

Usually we study this neuronal input following the presentation of a stimulus or following a cognitive event

What generates the currents and fields

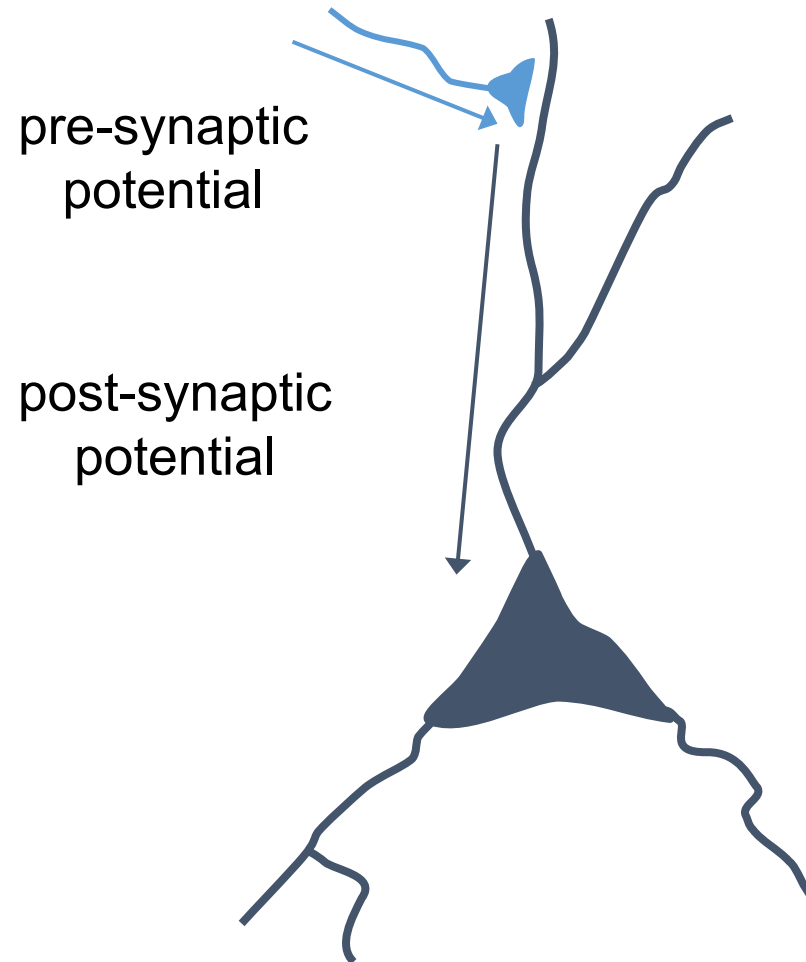

What generates the currents and fields

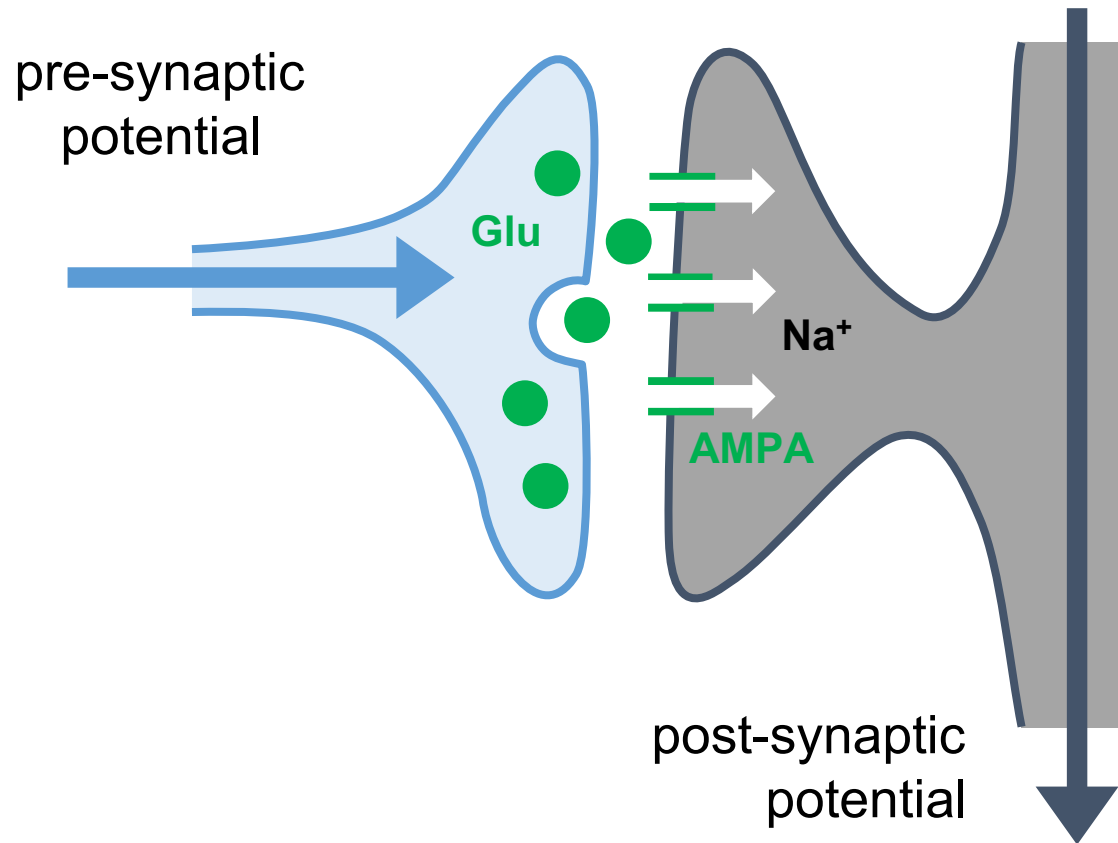

What generates the currents and fields

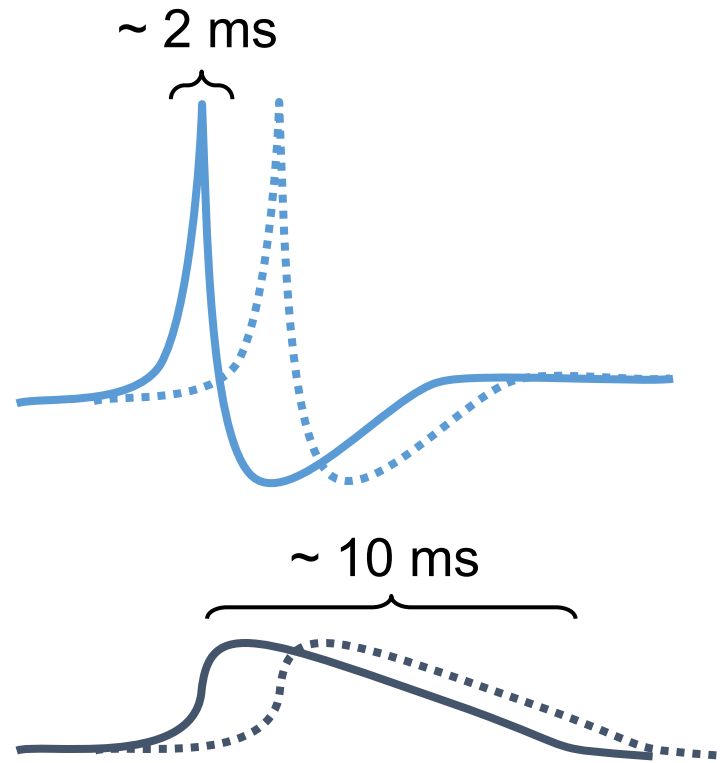

What generates the currents and fields

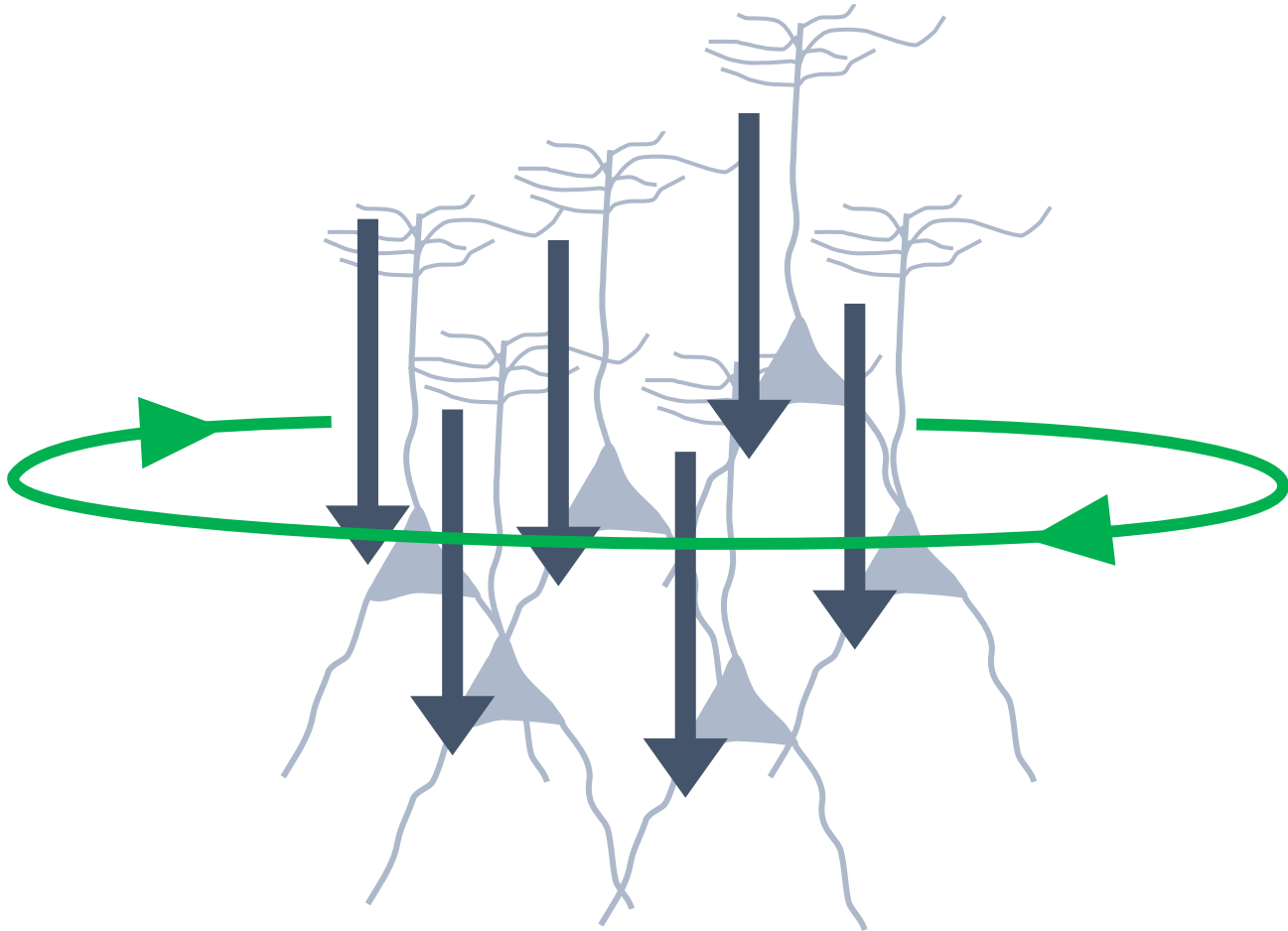

What generates the currents and fields

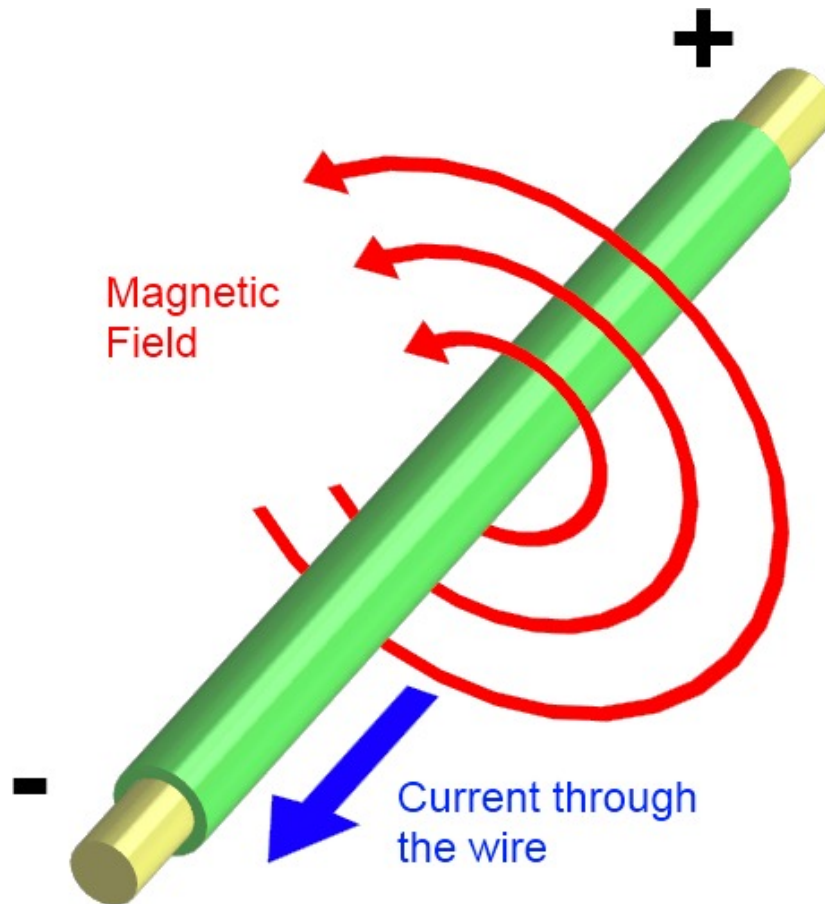

What generates the currents and fields

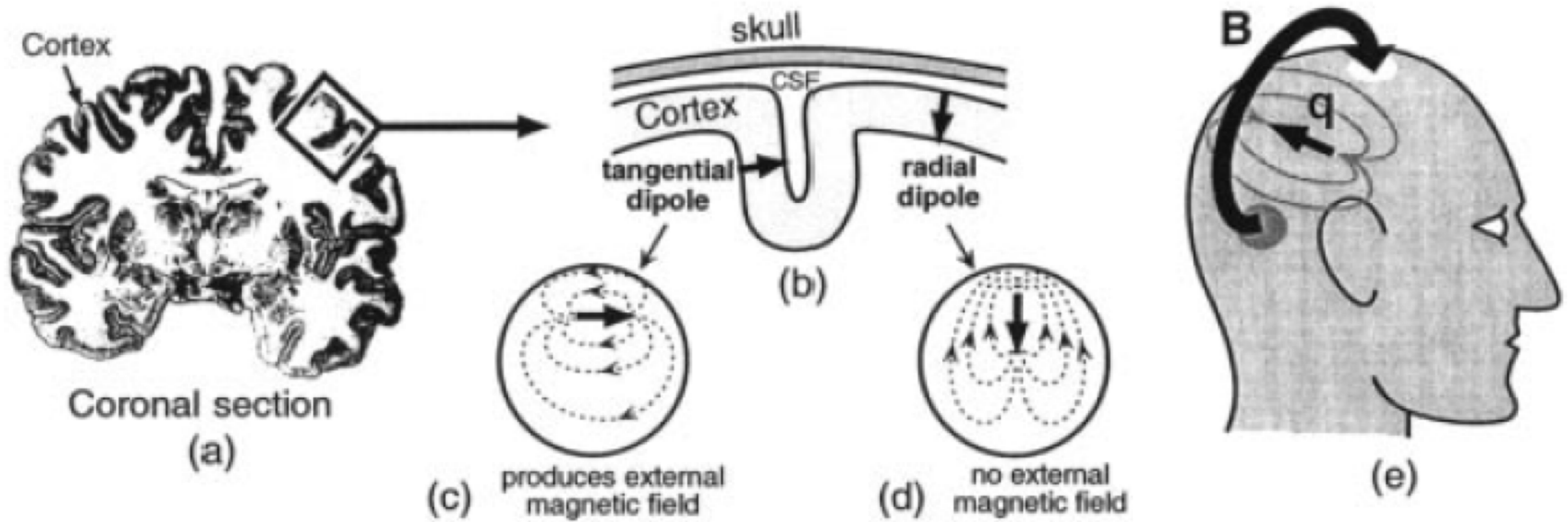

EEG volume conduction

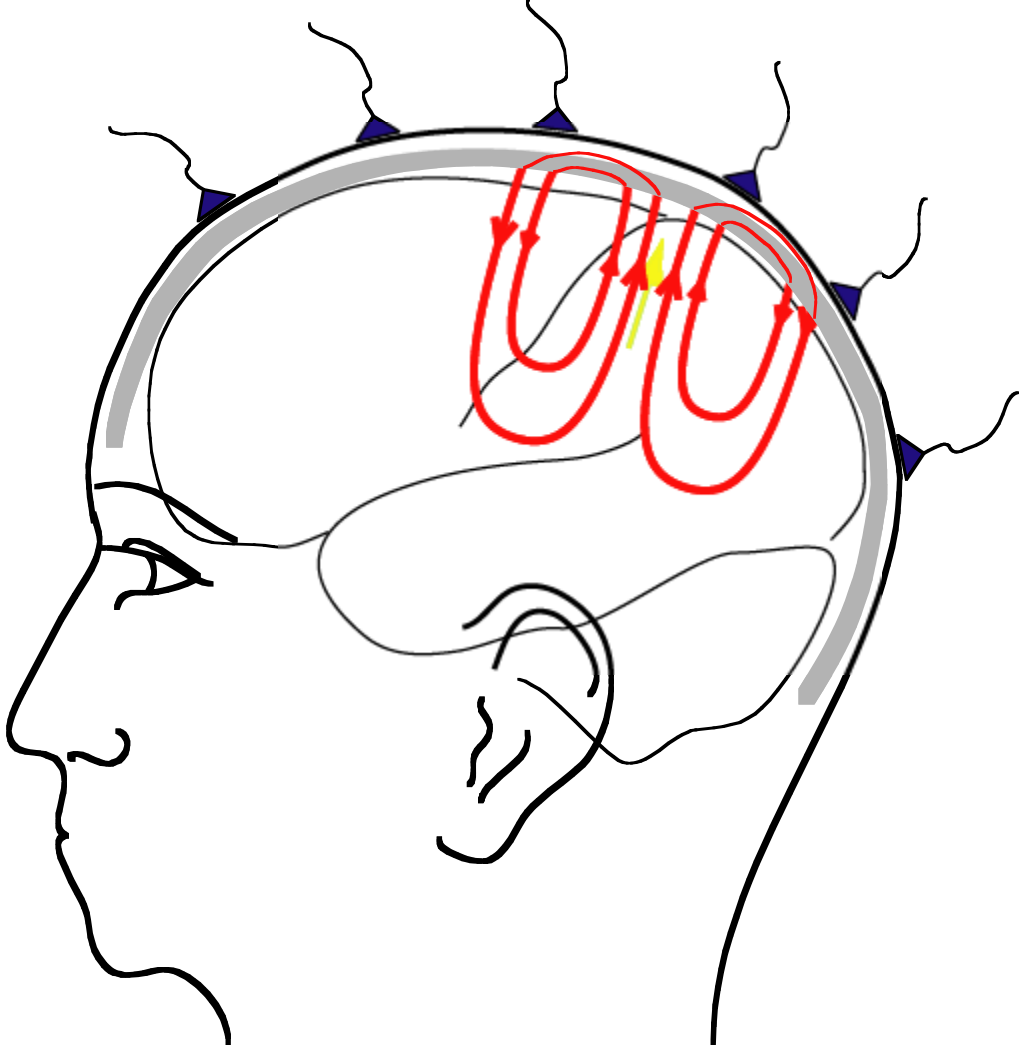

Electric current \rightarrow magnetic field

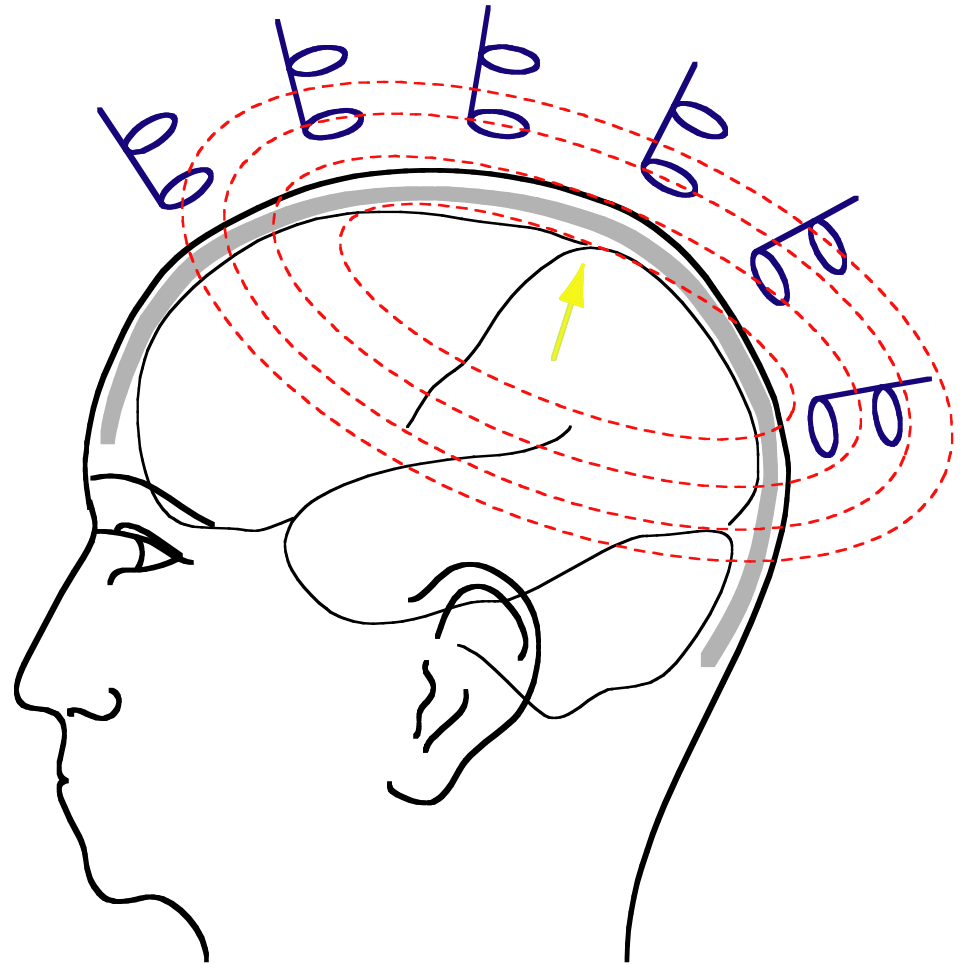
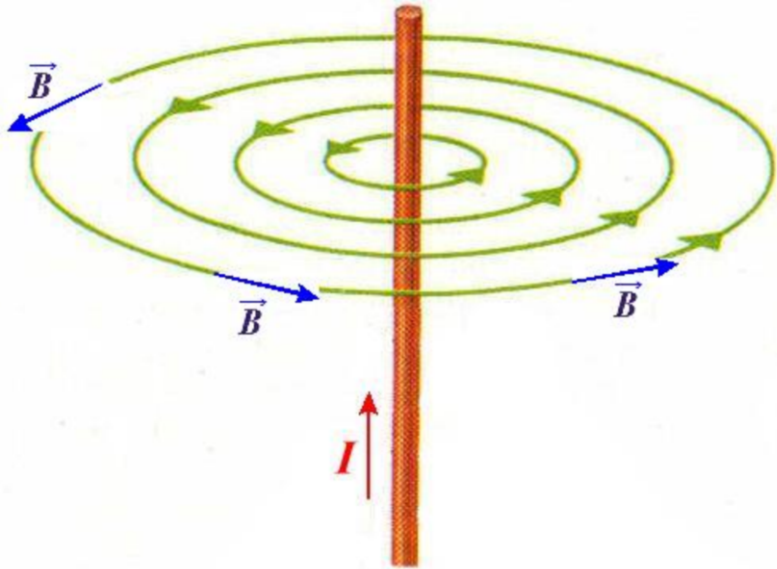

Talk outline

What kind of signals are generated in the brain

How do we record those signals

Analyzing those signals with FieldTrip

Background on the FieldTrip toolbox

How do we record these signals from the brain

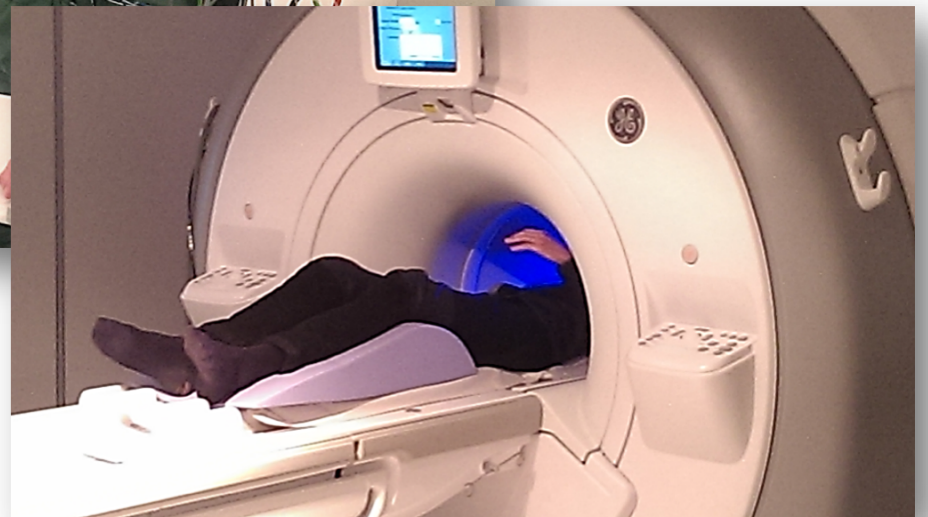
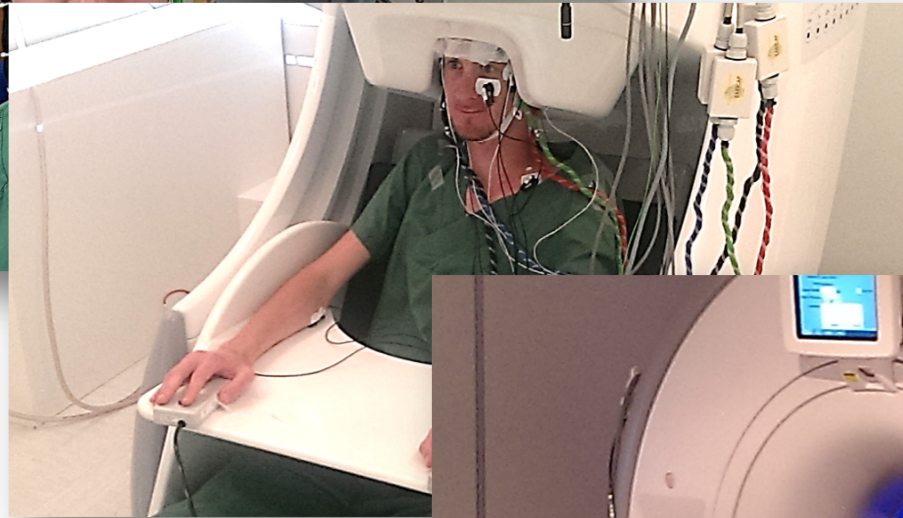
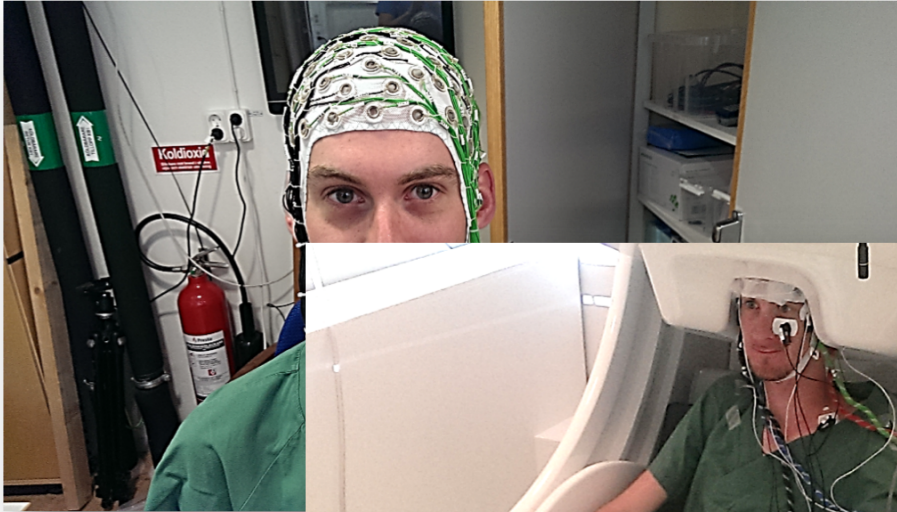

Recording small magnetic fields

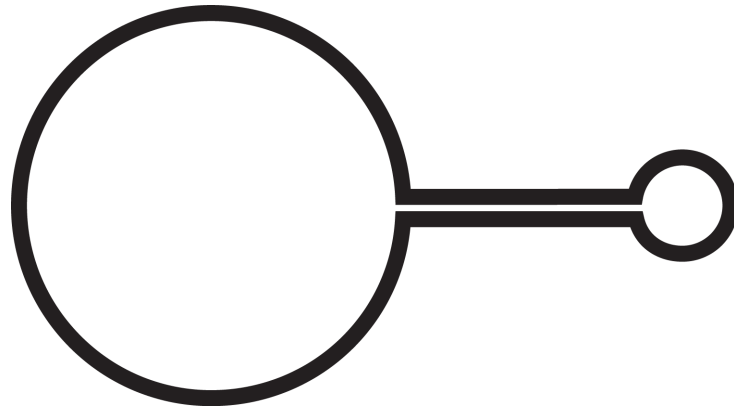

Recording small magnetic fields

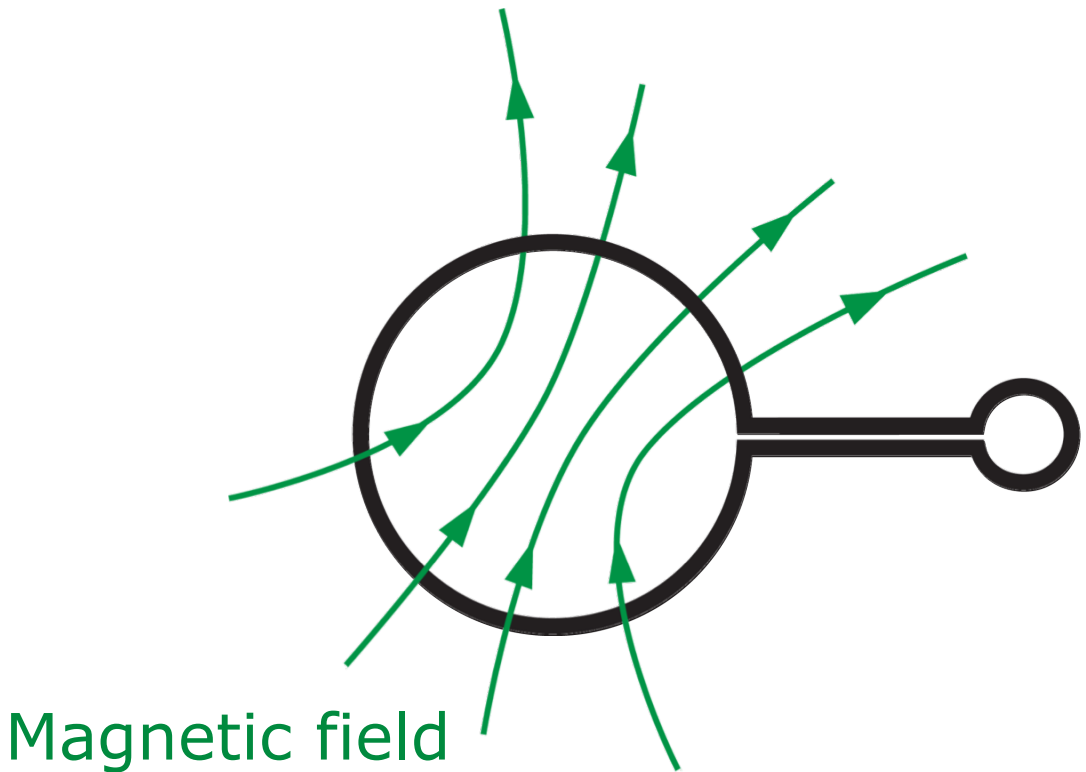

Recording small magnetic fields

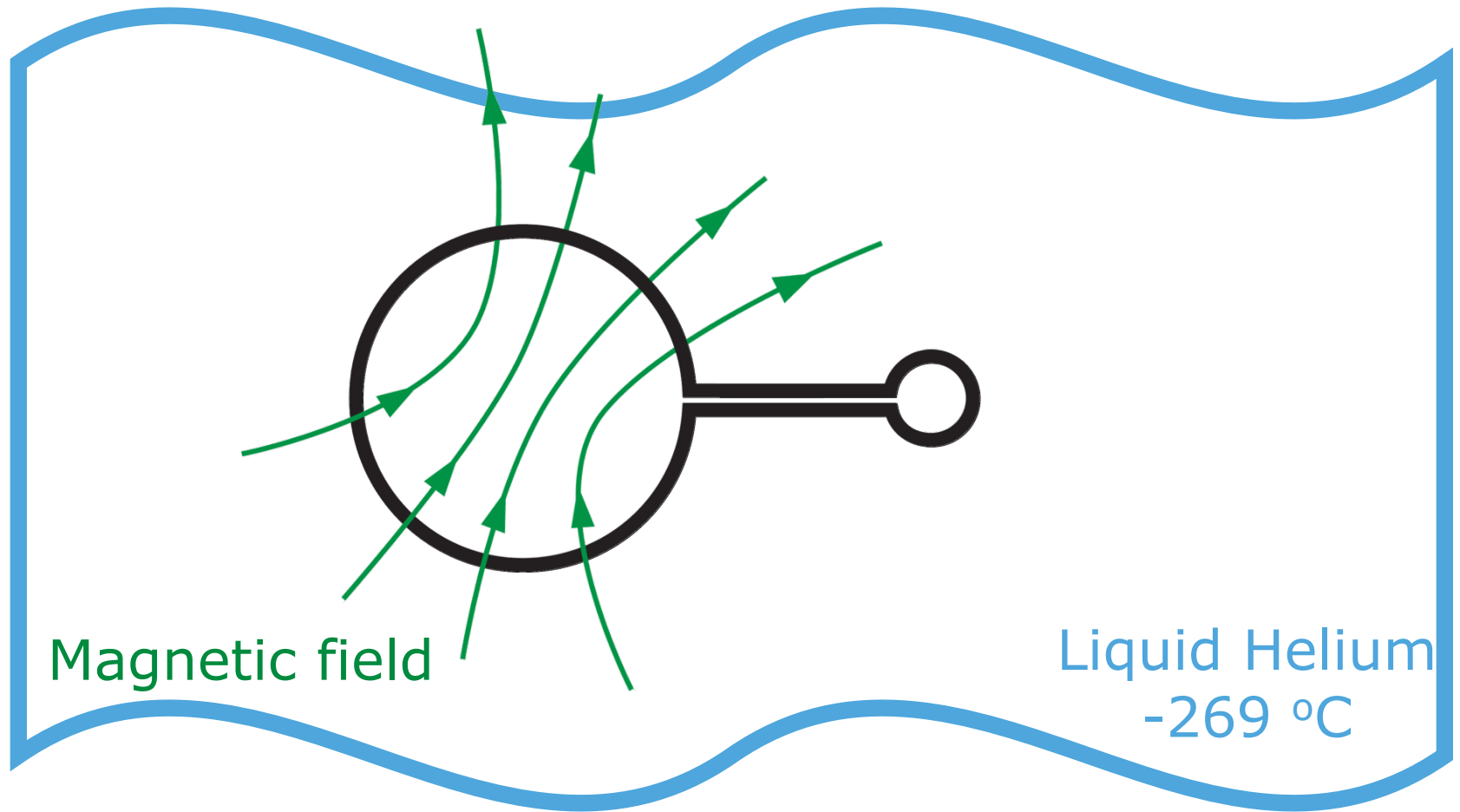

Recording small magnetic fields

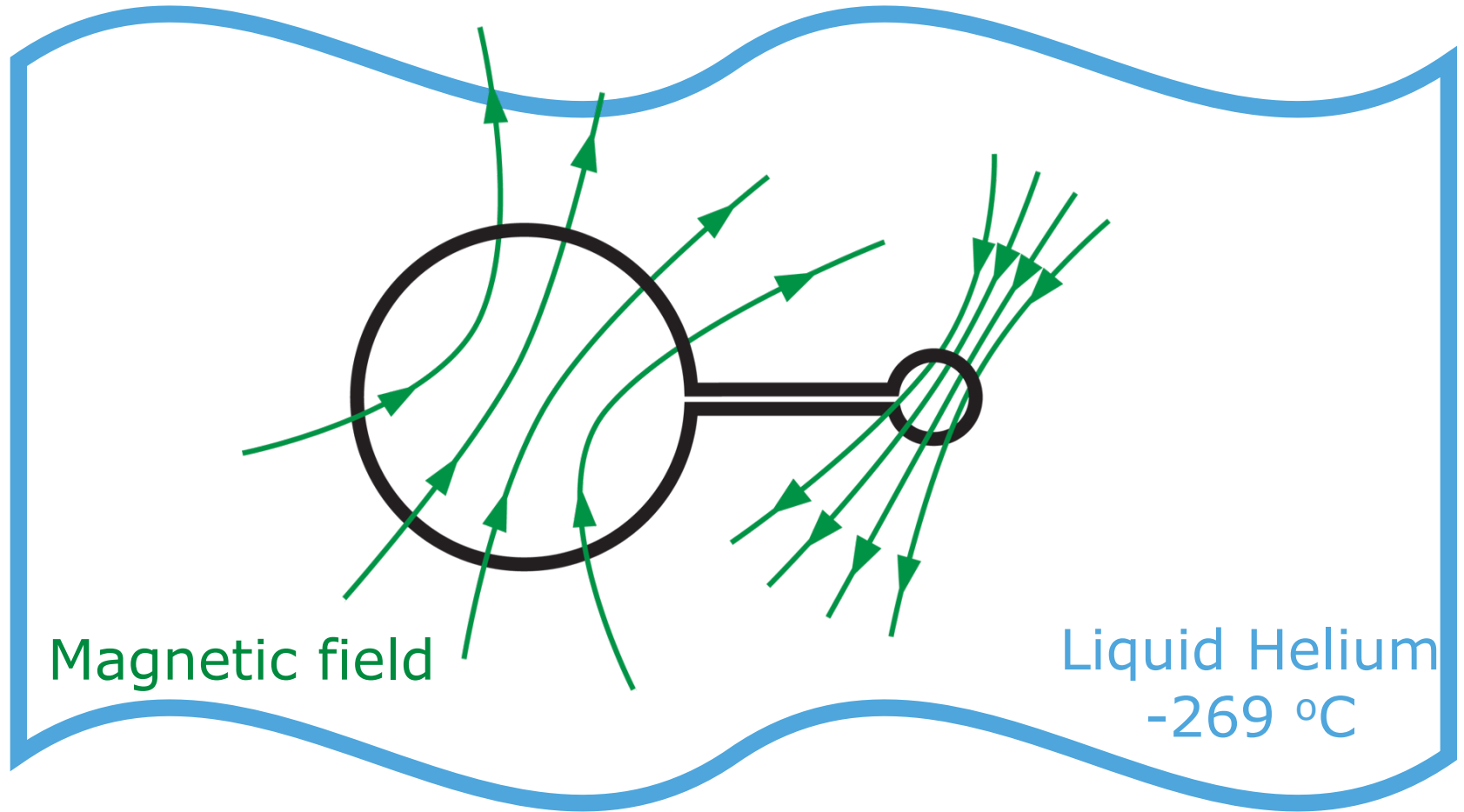

Recording small magnetic fields

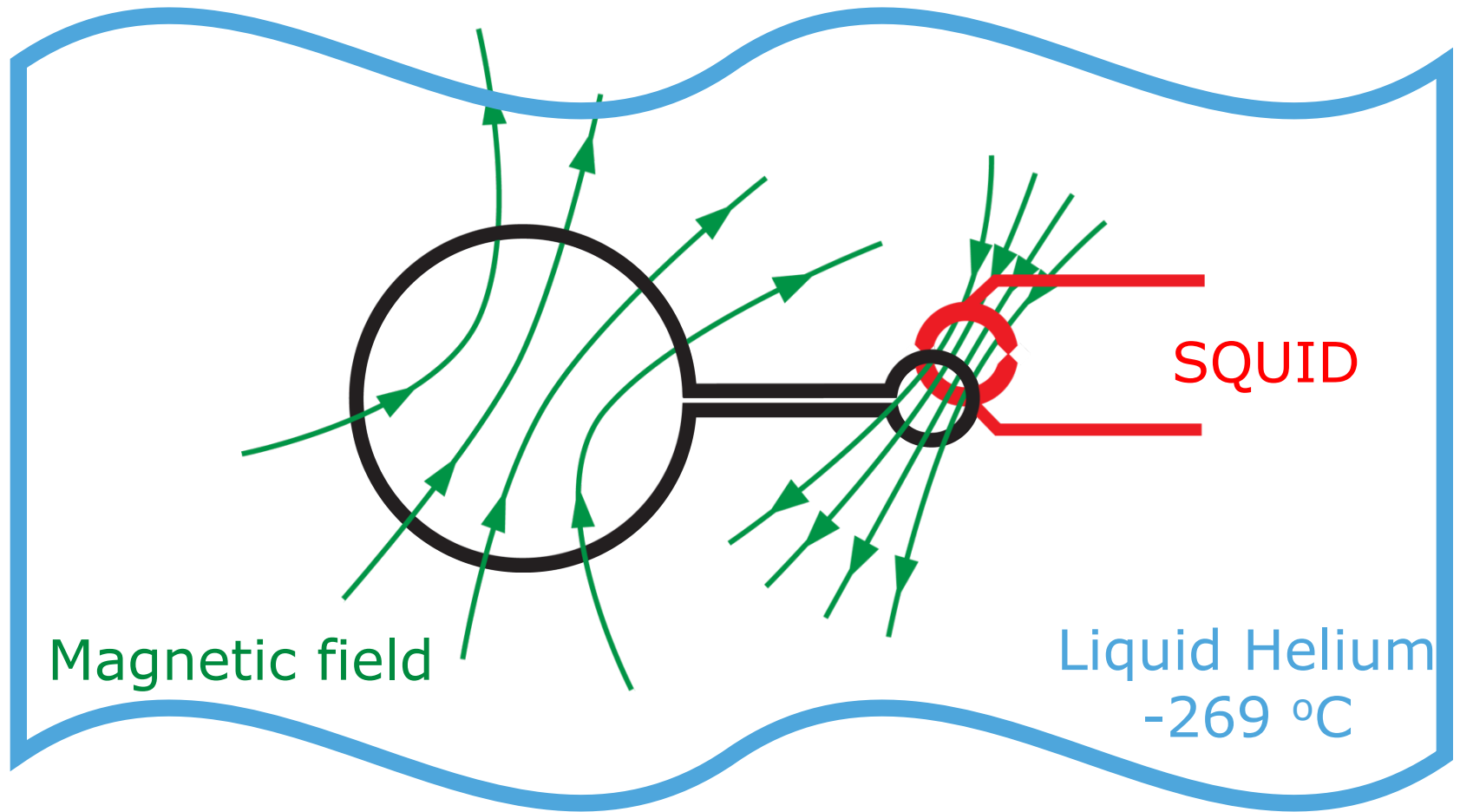

Magnetic field detectors

Superconducting **QU**antum **I**nterference **D**evice

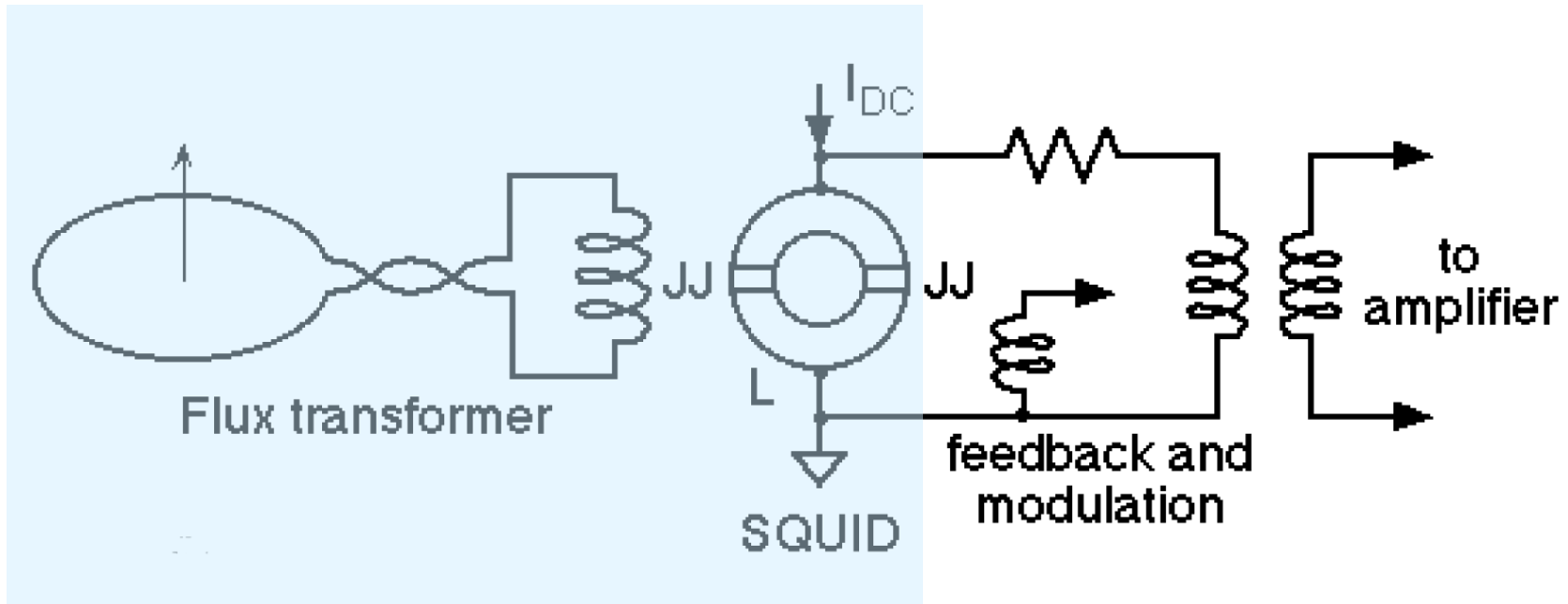
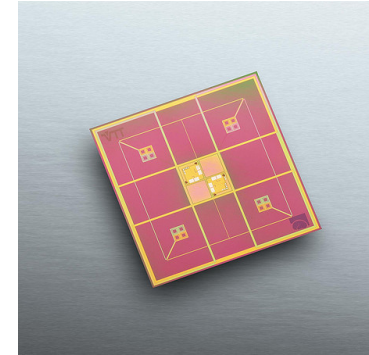

Magnetic field strength - compared

10^{-12}	0.1 - 1.0 picoTesla	human brain
10^{-9}	0.1 -10 nanoTesla	heliosphere
10^{-6}	24 microTesla	magnetic tape near tape head
10^{-5}	300-600 μ T microTesla	earth's magnetic field
10^{-3}	5 milliTesla	typical refrigerator magnet
10^0	1.5 - 7 Tesla	MRI systems

Technical challenges of MEG

Requires sensitive magnetic detectors

Deal with environmental noise

- shielding

- sensor design

- reference sensors for noise subtraction

Shielding - passive

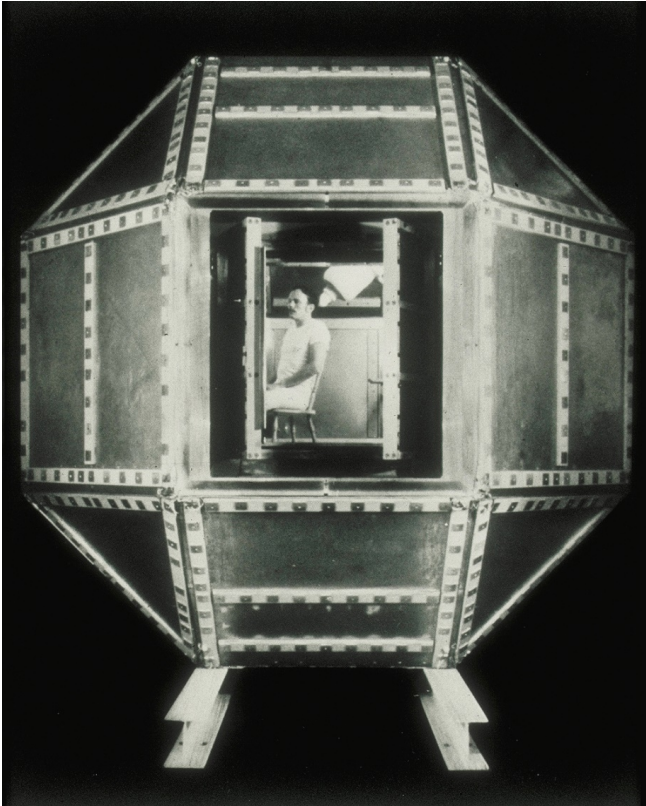

The magnetically shielded room built by David Cohen at MIT's Francis Bitter National Magnet Laboratory in 1969.

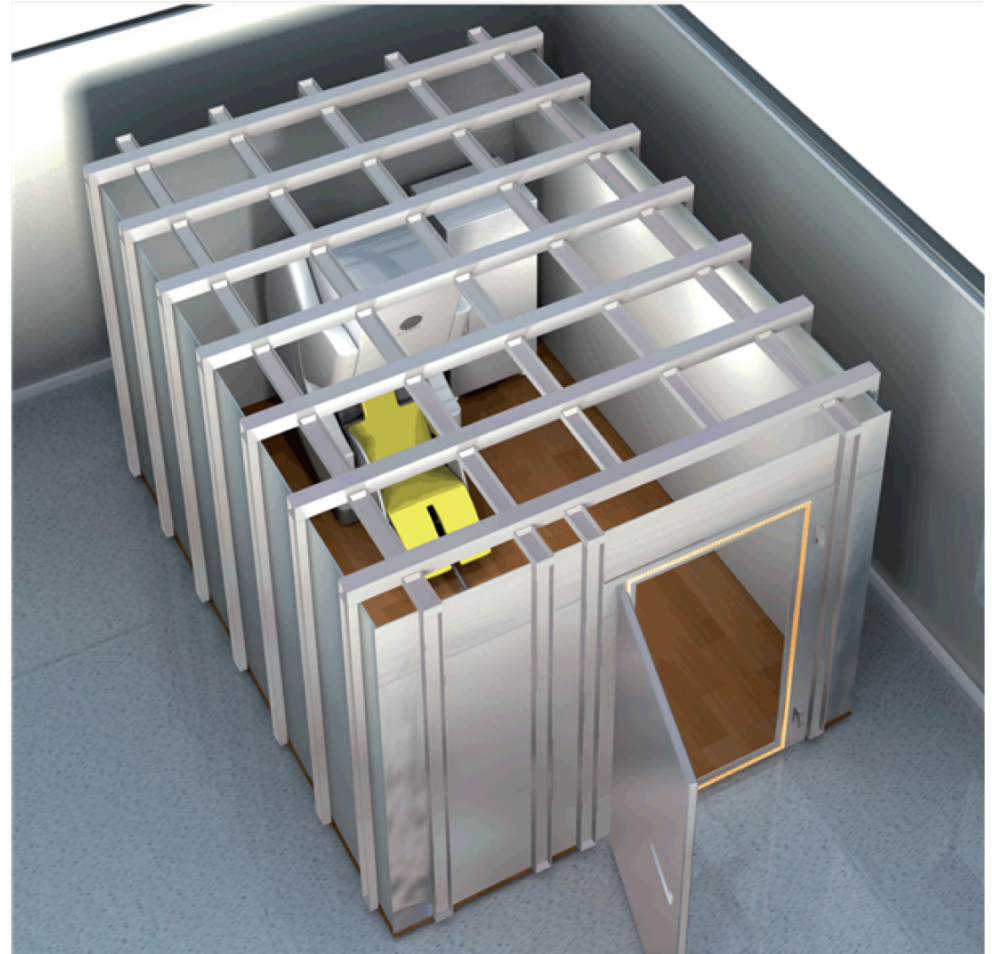

Shielding - active

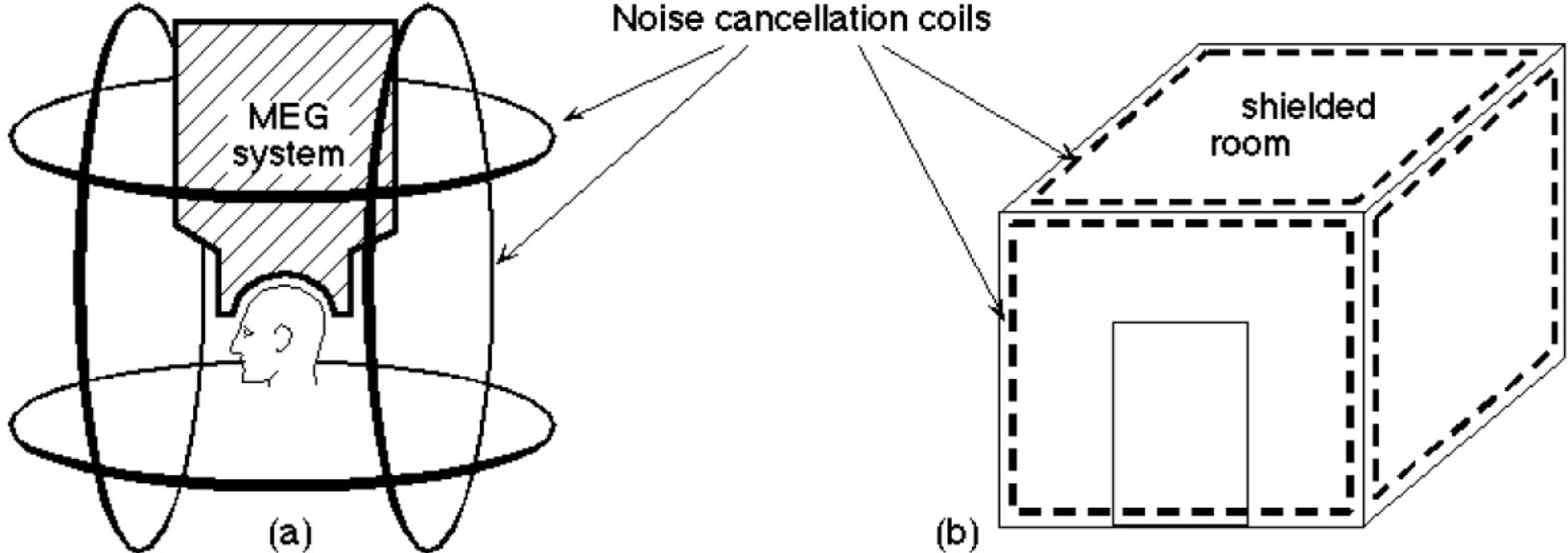

Magnetometer

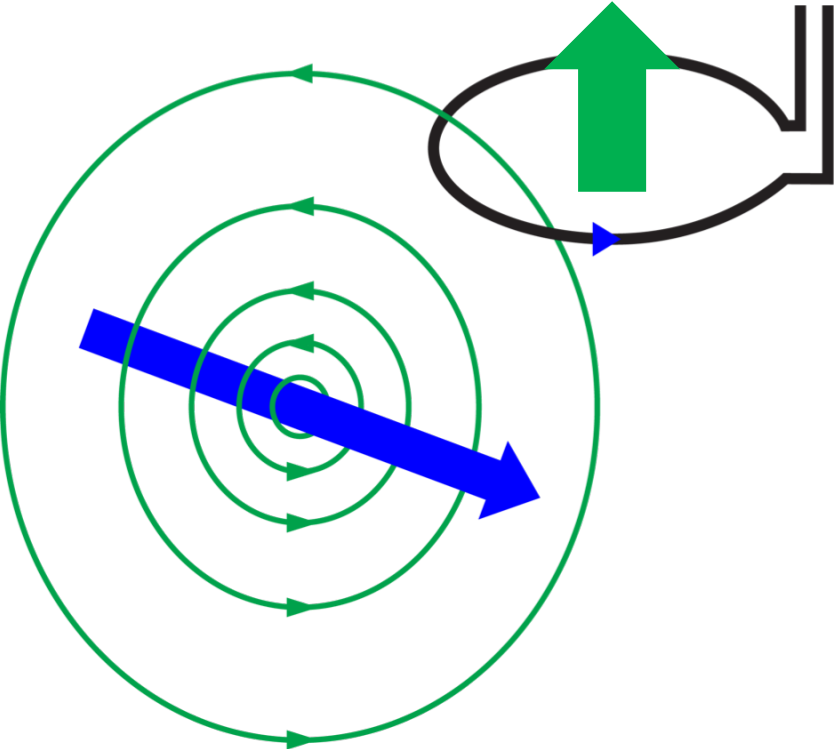

Magnetometer

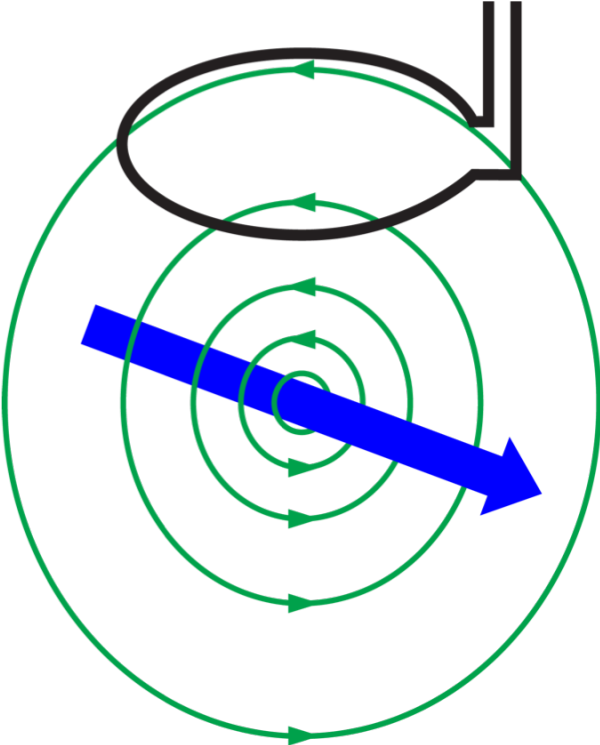

Magnetometer

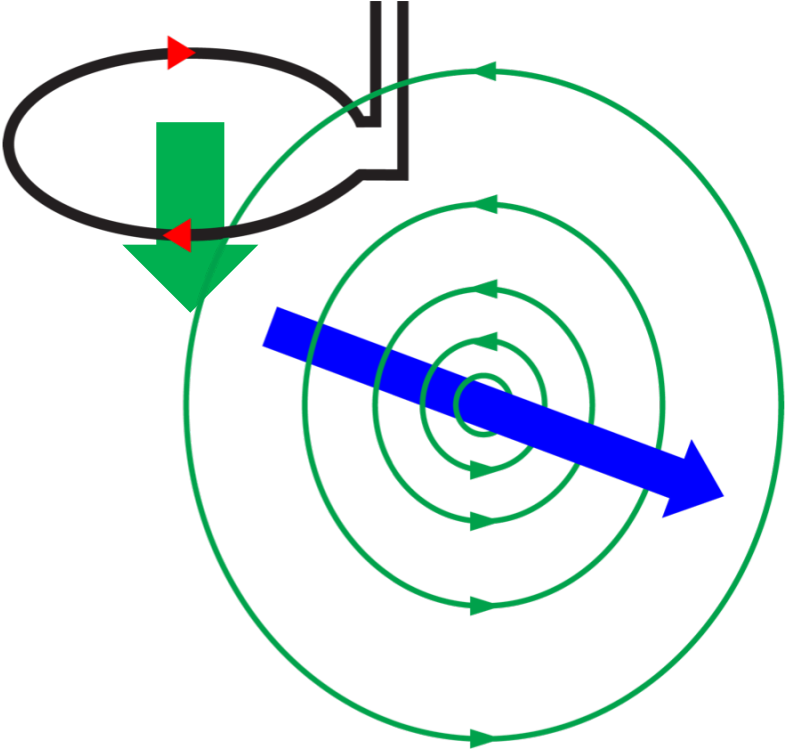

Planar gradiometer

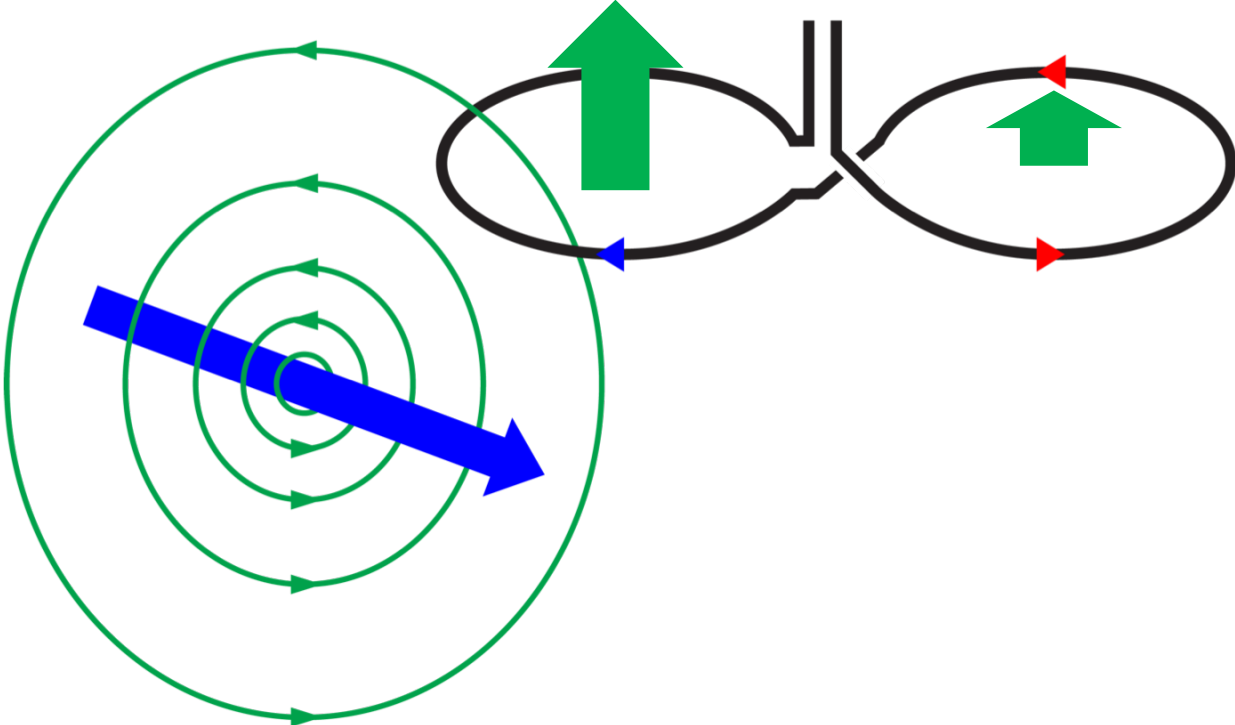

Planar gradiometer

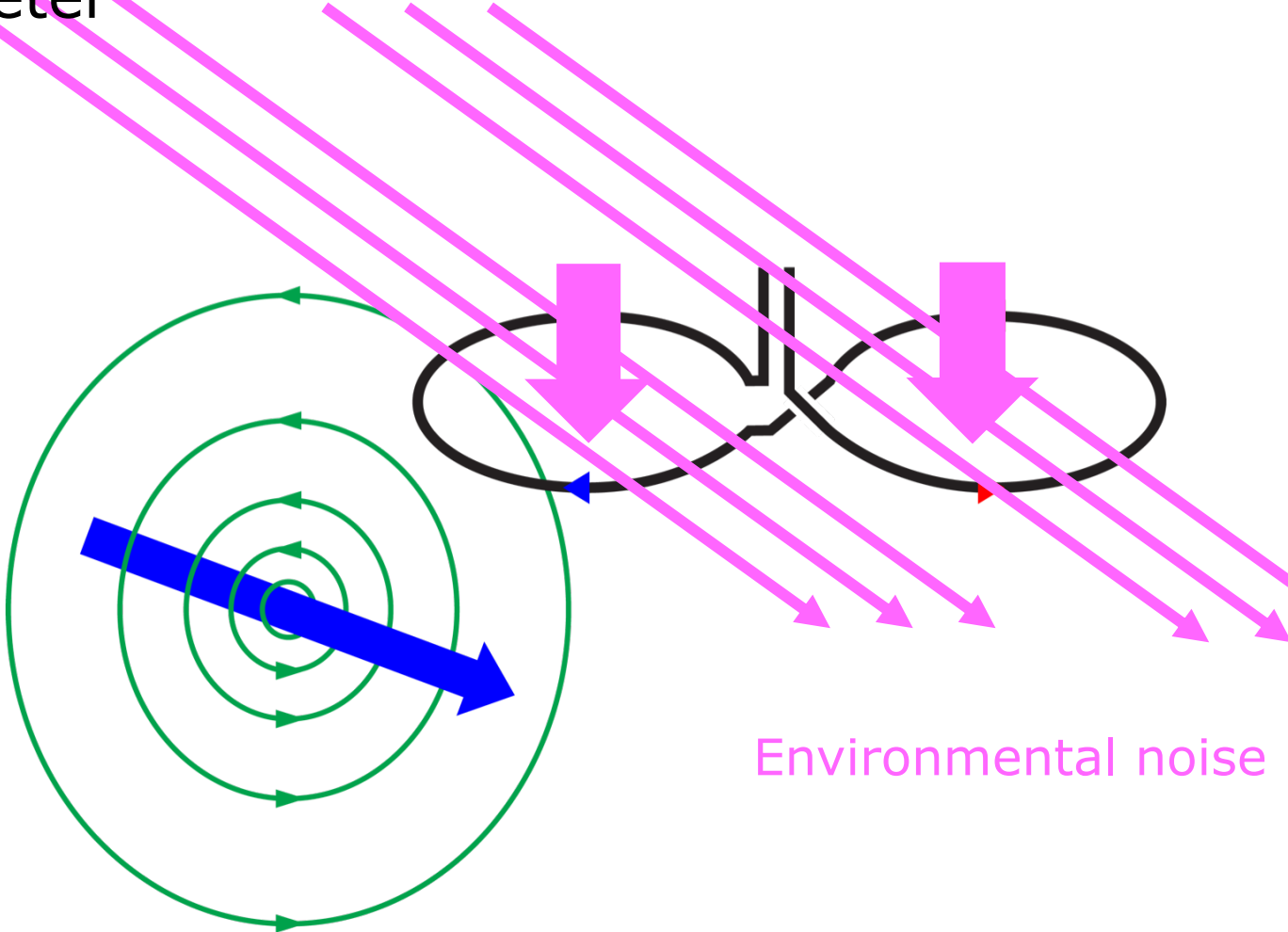

Environmental noise

Planar gradiometer

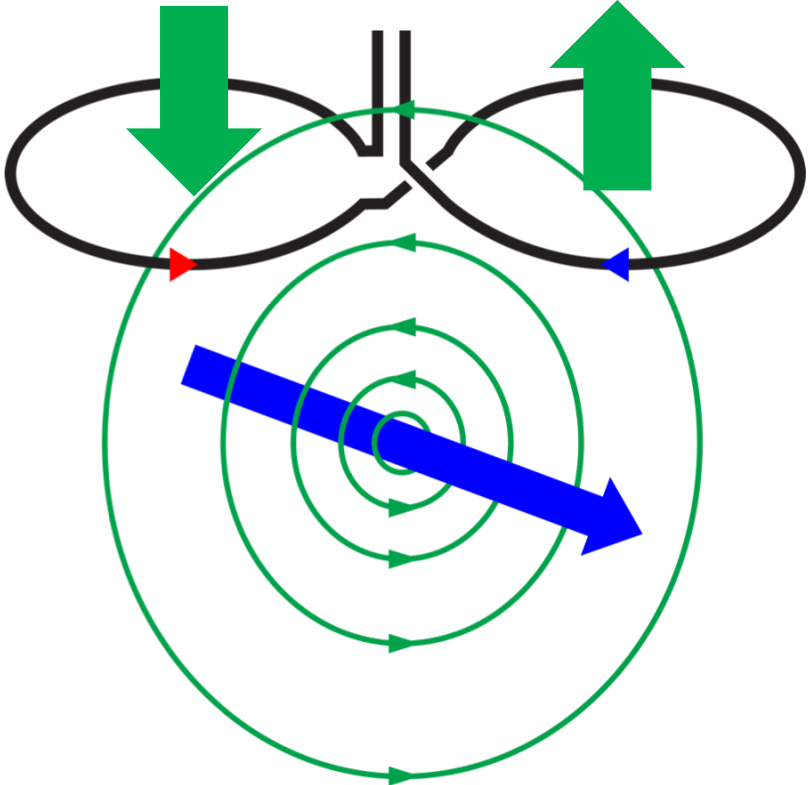

Axial gradometer

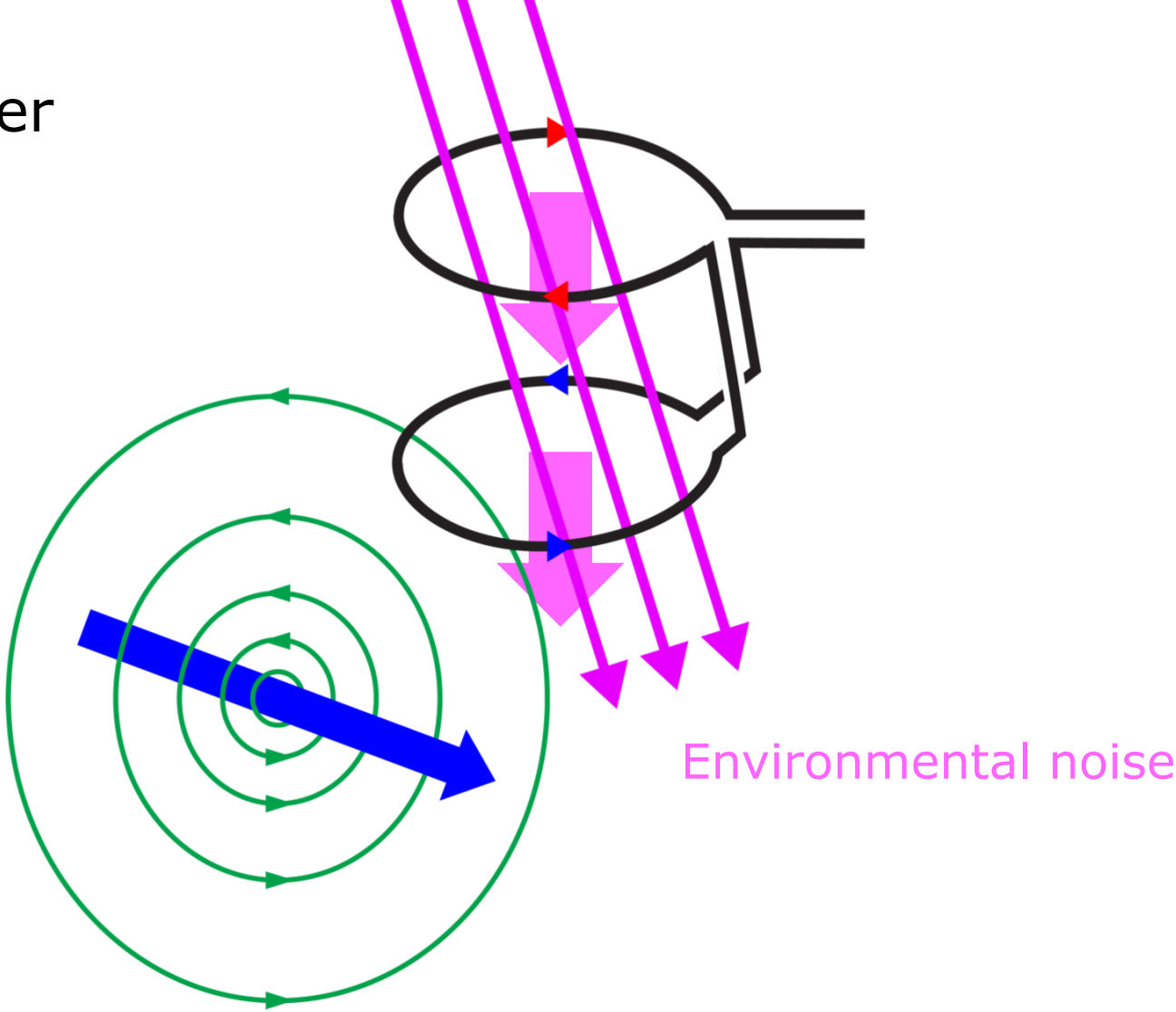

MEG sensor – sensitivity profile

Magnetometer

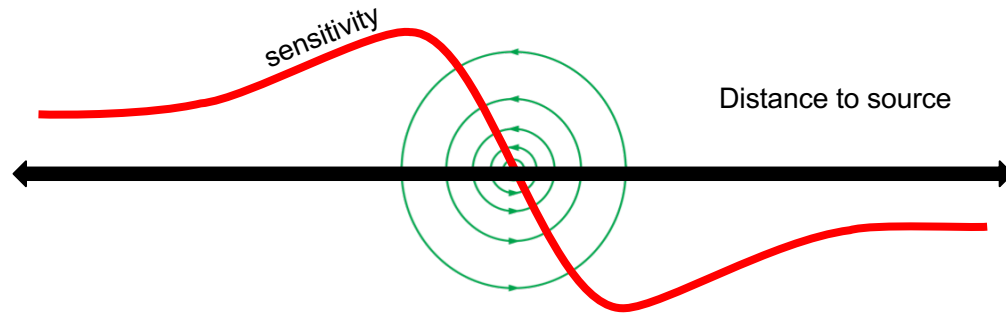
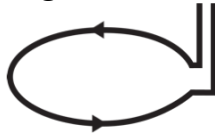

Axial gradiometer

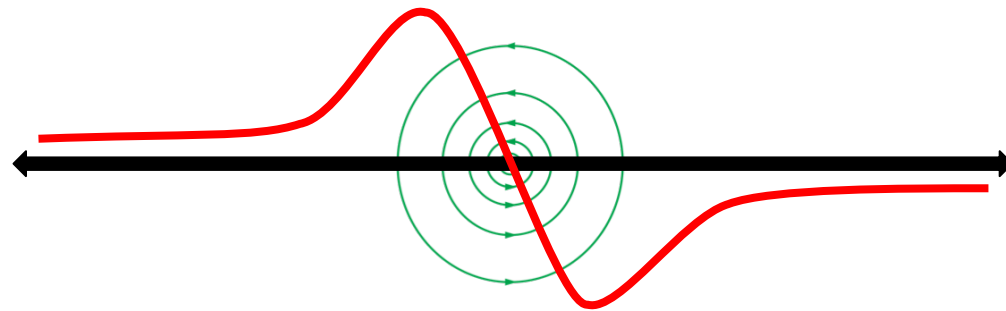
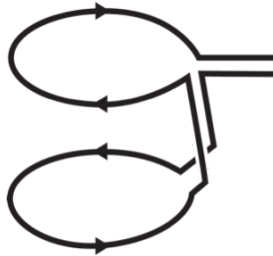

Planar gradiometer

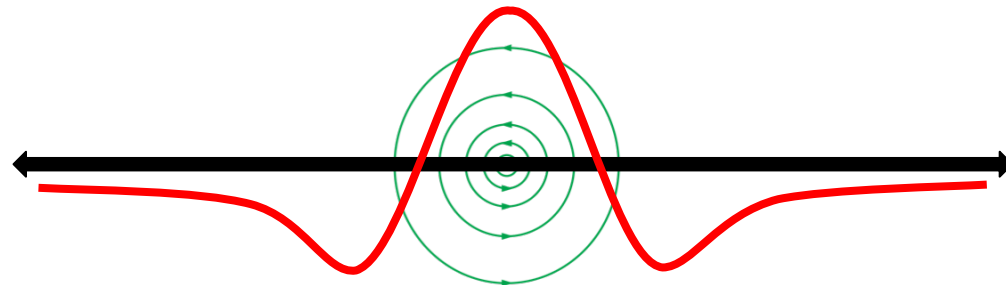

MEG systems

about 100-150 installations worldwide
two in the Netherlands



Elekta Neuromag

102 magnetometers
204 planar gradiometers
306 channels total

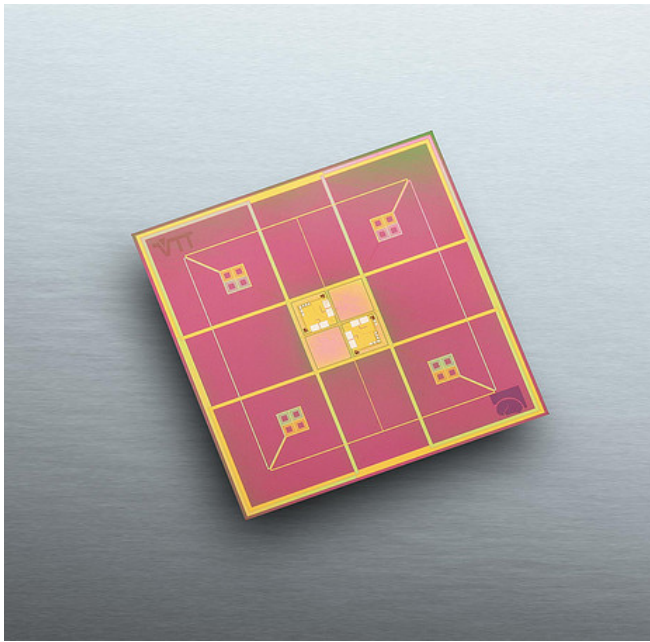

Elekta Neuromag

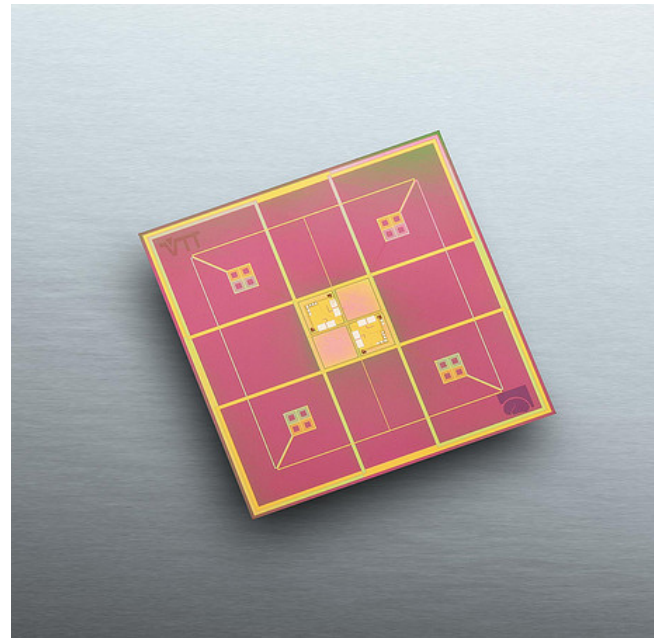
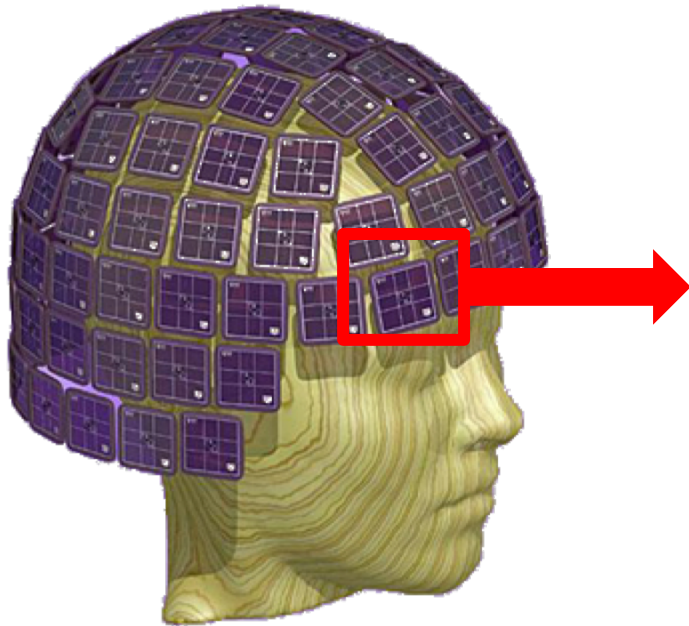

Elekta Neuromag

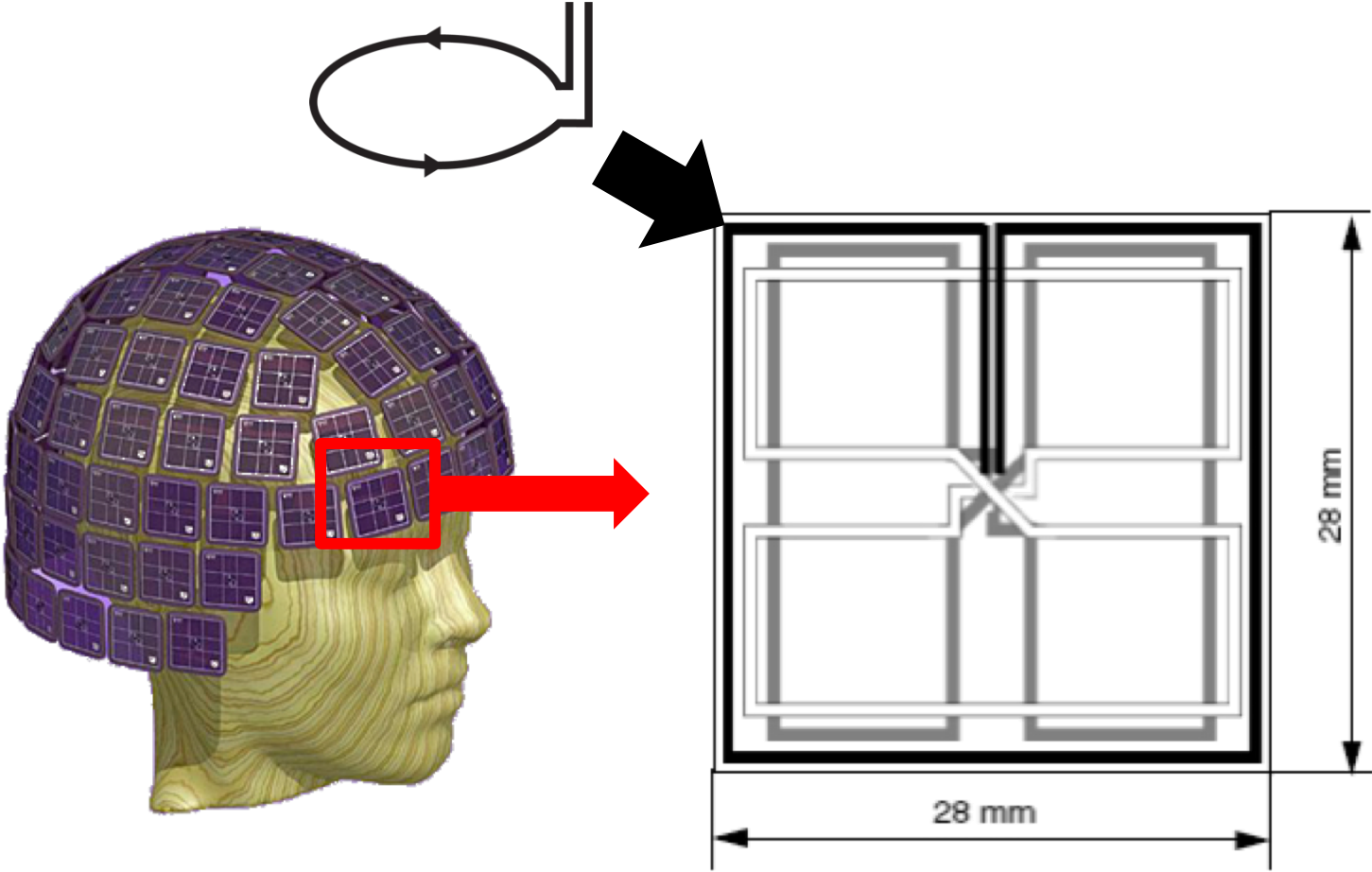

Elekta Neuromag

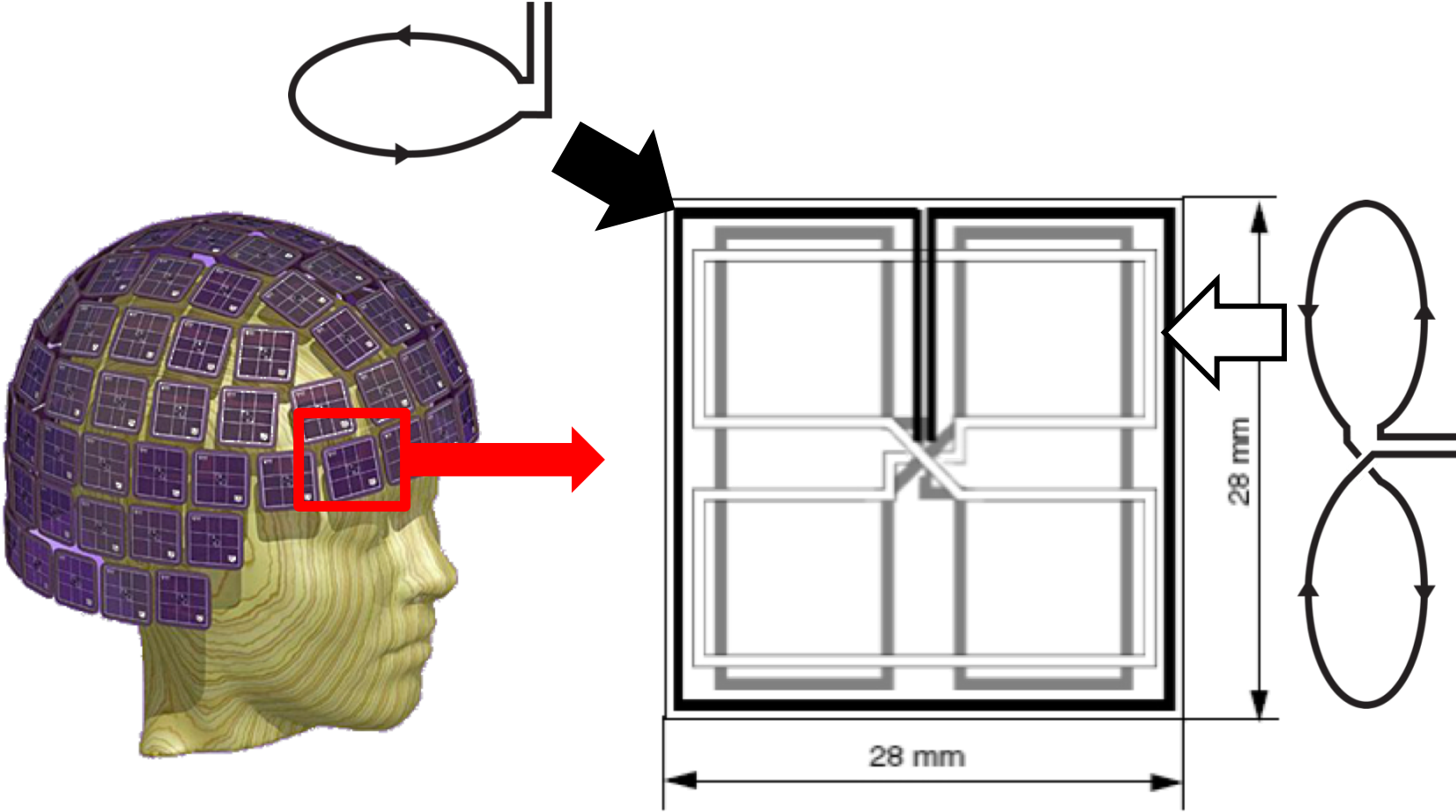

Elekta Neuromag

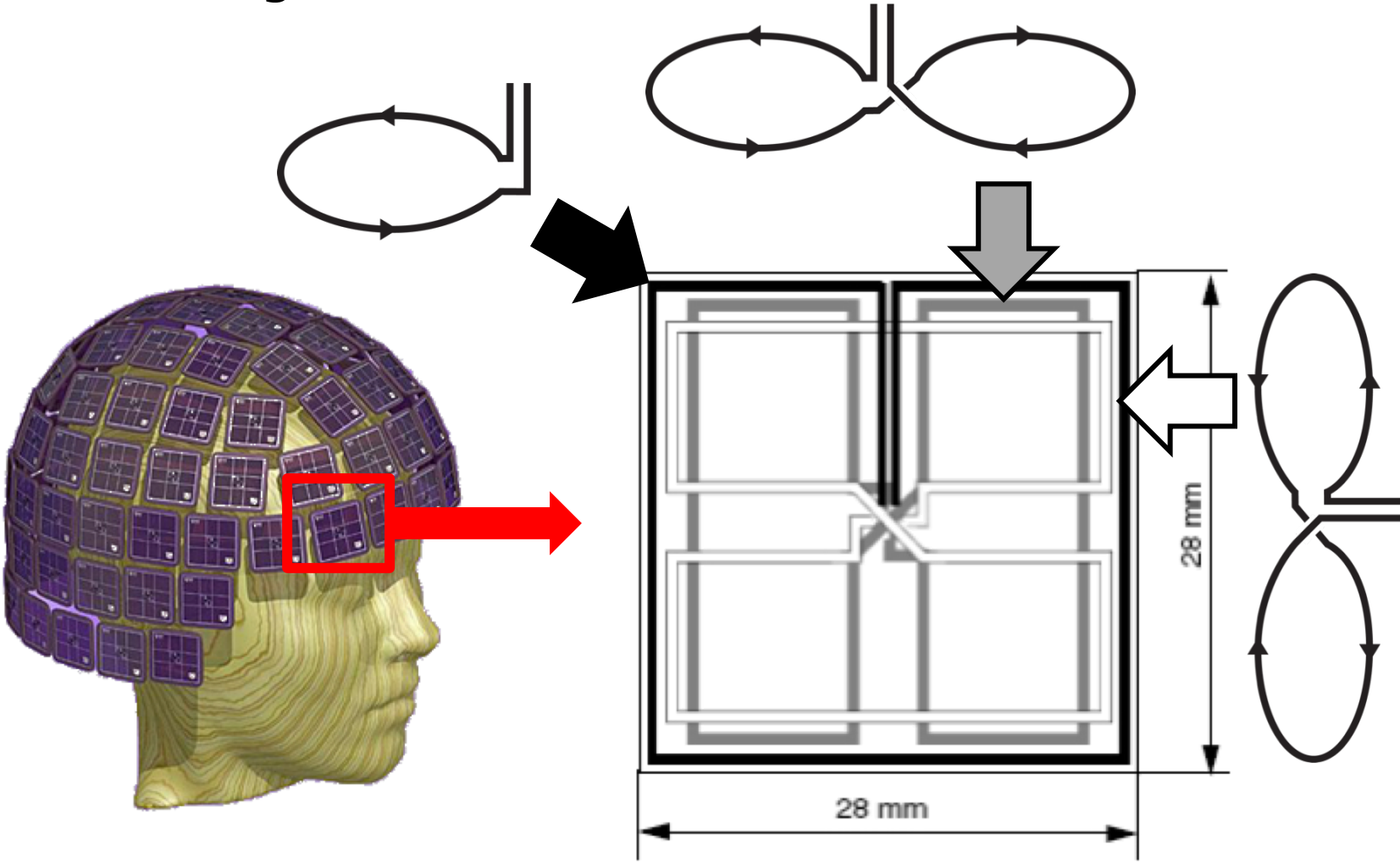

Elekta Neuromag

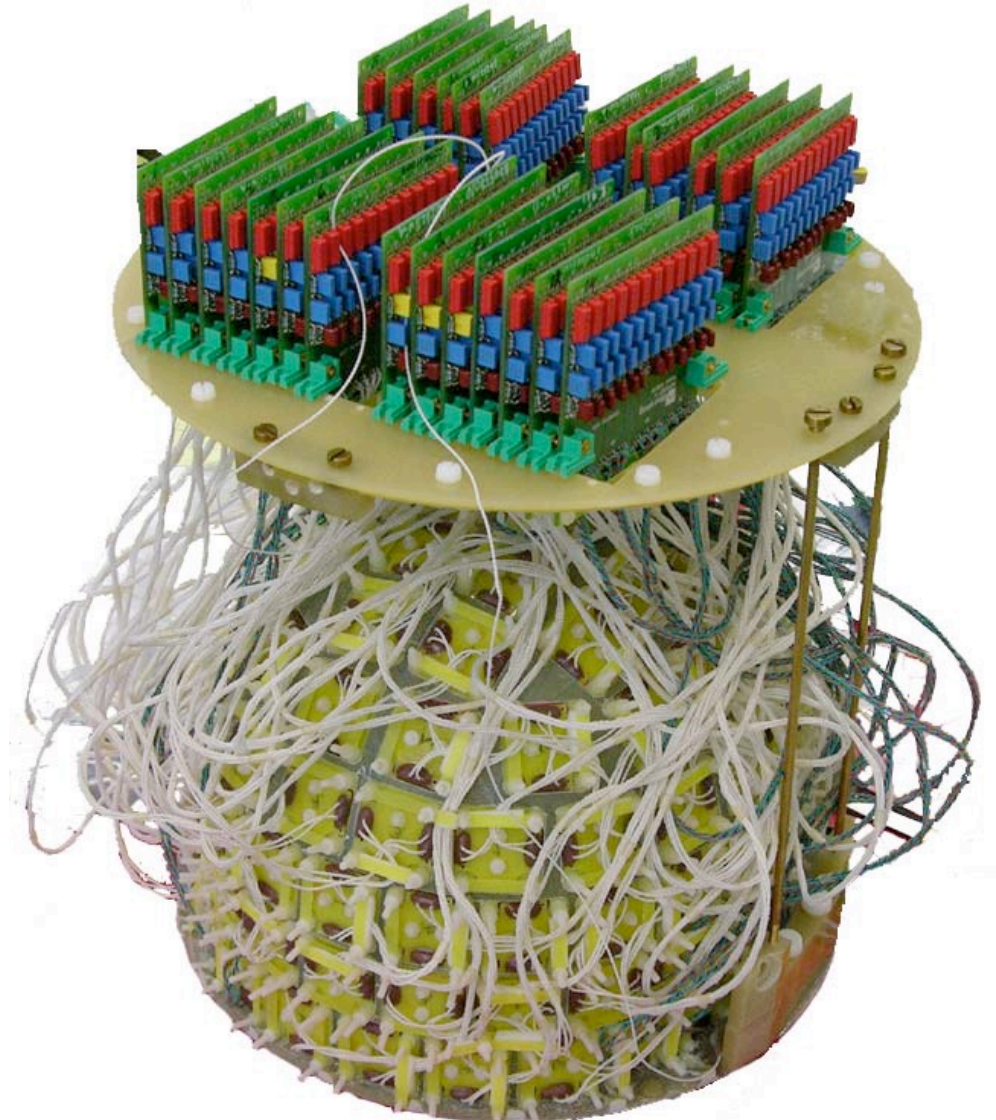
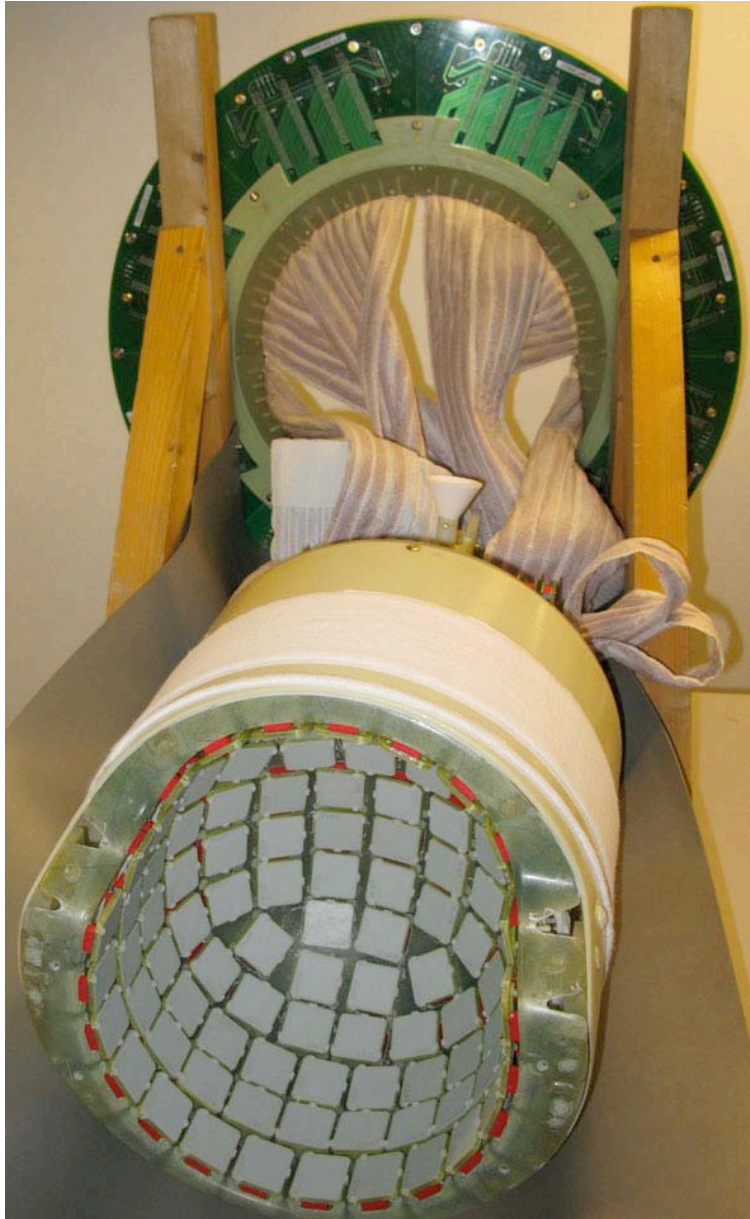

N400 response in MEG

18Jun2003

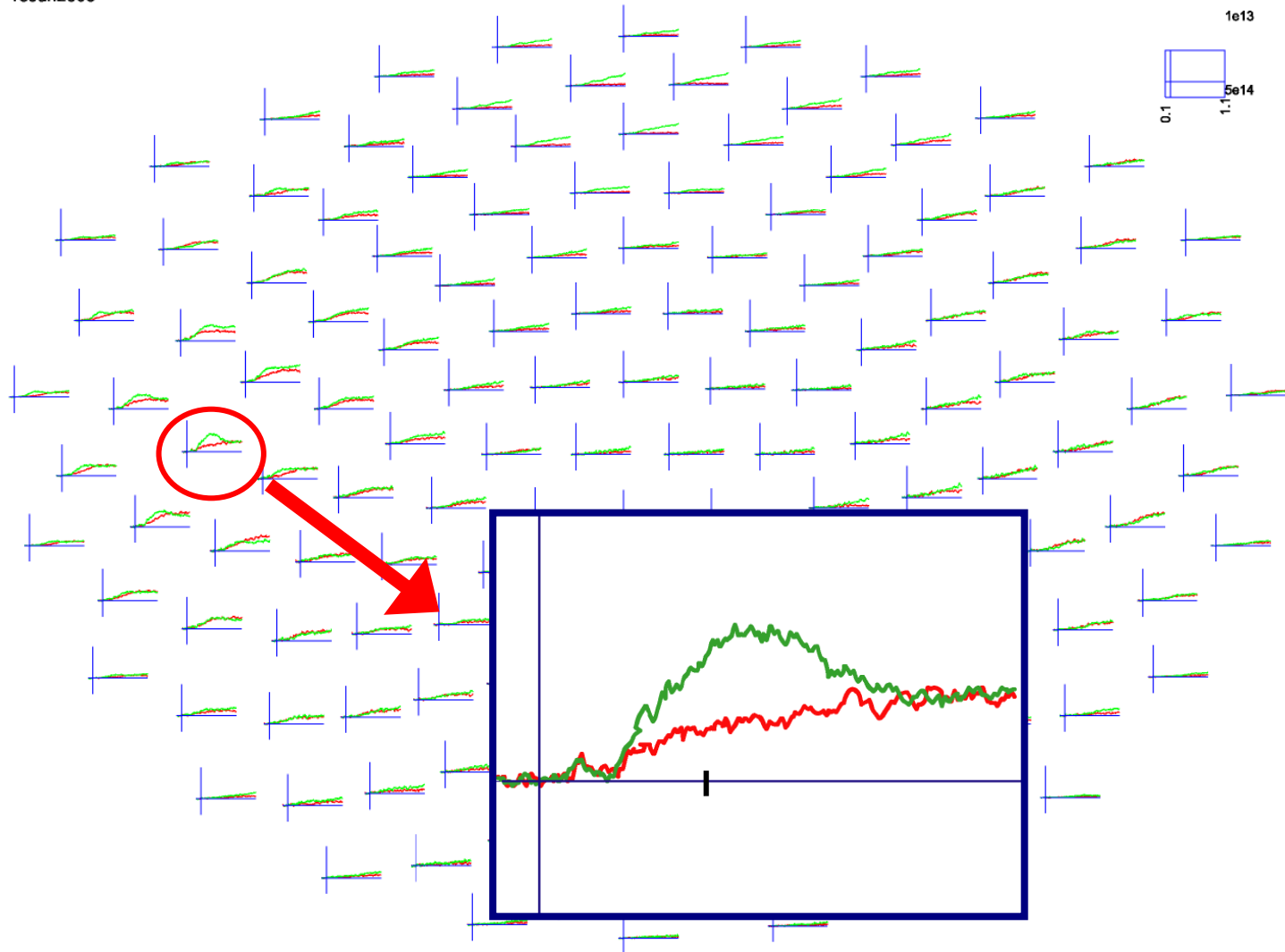

N400 response - compared between MEG systems

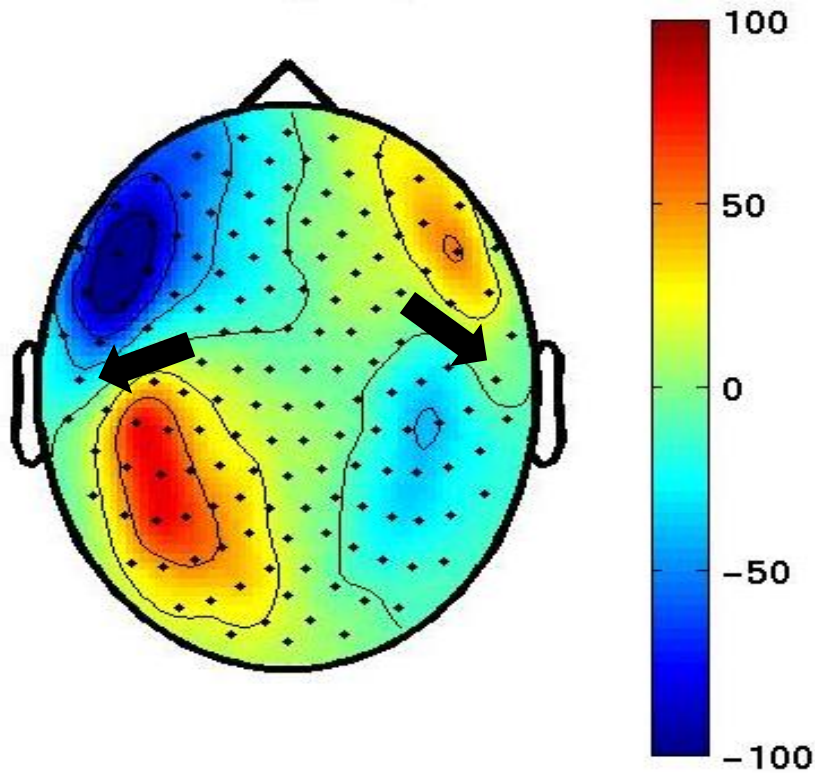

axial magnetic field

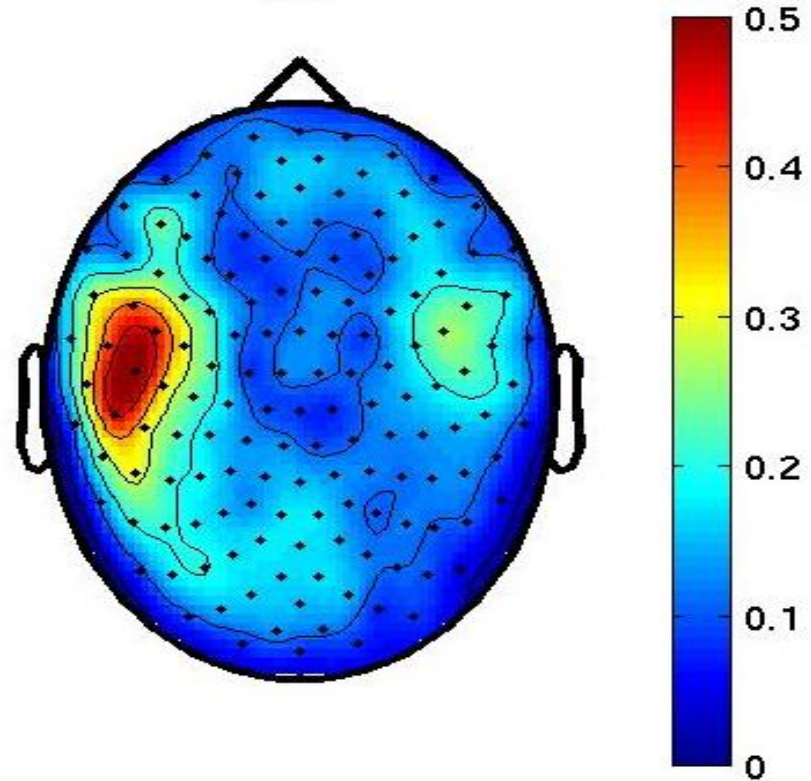

planar gradient

N400 response - compared between MEG and EEG

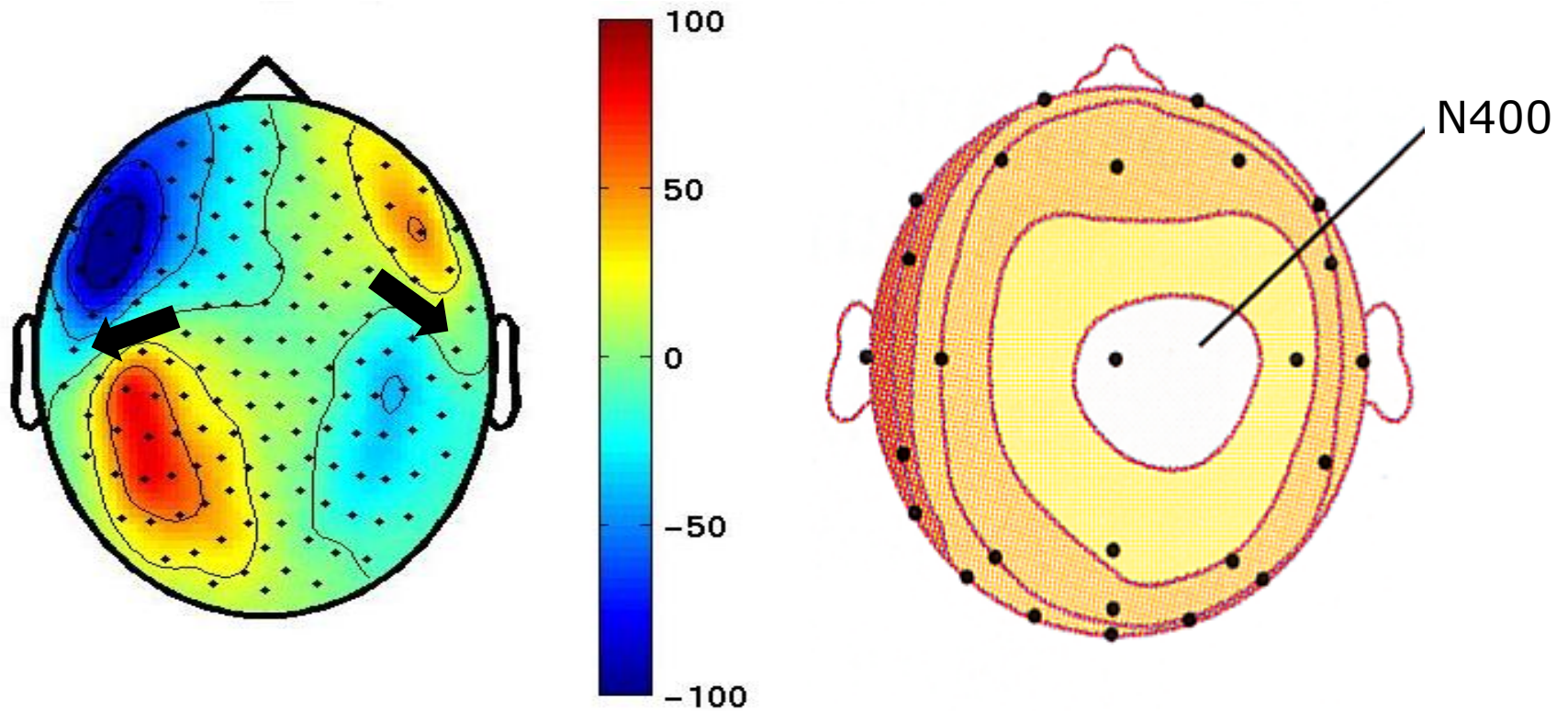

axial magnetic field

potential distribution

Moving magnetoencephalography towards real-world applications with a wearable system

Elena Boto^{1*}, Niall Holmes^{1*}, James Leggett^{1*}, Gillian Roberts^{1*}, Vishal Shah², Sofie S. Meyer^{3,4}, Leonardo Duque Muñoz³, Karen J. Mullinger^{1,5}, Tim M. Tierney³, Sven Bestmann^{3,6}, Gareth R. Barnes⁷, Richard Bowtell^{1,8} & Matthew J. Brookes^{1,8}

Imaging human brain function with techniques such as magnetoencephalography¹ typically requires a subject to perform tasks while their head remains still within a restrictive scanner. This artificial environment makes the technique inaccessible to many people, and limits the experimental questions that can be addressed. For example, it has been difficult to apply neuroimaging to investigation of the neural substrates of cognitive development in babies and children, or to study processes in adults that require unconstrained head movement (such as spatial navigation). Here we describe a magnetoencephalography system that can be worn like a helmet, allowing free and natural movement during scanning. This is possible owing to the integration of quantum sensors^{2,3}, which do not rely on superconducting technology, with a system for nulling background magnetic fields. We demonstrate human electrophysiological measurement at millisecond resolution while subjects make natural movements, including head nodding,

stretching, drinking and playing a ball game. Our results compare well to those of the current state-of-the-art, even when subjects make large head movements. The system opens up new possibilities for scanning any subject or patient group, with myriad applications such as characterization of the neurodevelopmental connectome, imaging subjects moving naturally in a virtual environment and investigating the pathophysiology of movement disorders.

Magnetoencephalography¹ (MEG) allows direct imaging of human brain electrophysiology by measurement of magnetic fields generated at the scalp by neural currents. Mathematical analysis of those fields enables the generation of 3D images that show the formation and dissolution of brain networks in real time. MEG measurements of brain activity are currently made using an array of superconducting sensors placed around the head^{1,4}. These cryogenically cooled sensors have femtotesla (fT) sensitivity, which is needed to detect the weak magnetic fields produced by the brain. Unfortunately, the requirement

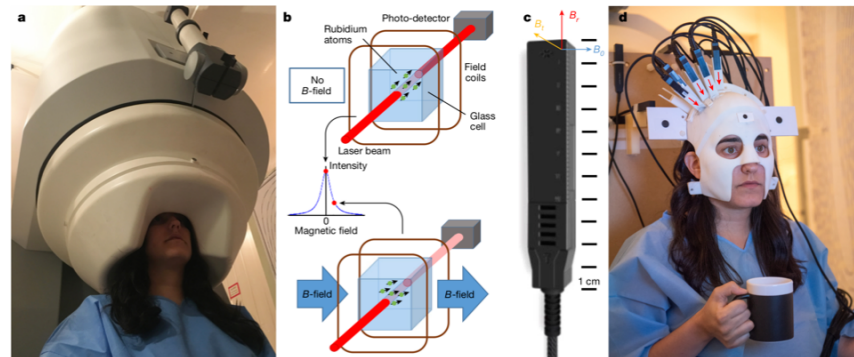

Figure 1 | A new generation of MEG system. **a**, A conventional 275-channel cryogenic MEG system. Weighing about 450 kg, the system is fixed and cumbersome and subjects must remain still relative to the fixed sensor array. **b**, Schematic illustration of zero-field resonance in an OPM sensor. Top, operation in zero-field; bottom, Larmor precession when an external field (B -field) impinges on the cell and the transmitted light intensity is reduced. **c**, A commercial OPM sensor made by QuSpin. The geometry used is illustrated by the coloured axes where B_r is the radial

field component, B_t the tangential field component and B_z the direction along which the laser beam is oriented. **d**, Our prototype OPM-MEG system helmet. The helmet weighs 905 g and is customized so that the sensors (which in this prototype cover only the right sensorimotor cortex) are directly adjacent to the scalp surface. The subject is free to move their head. The measured radial field direction for the sensors is illustrated by the red arrows.

¹Sir Peter Mansfield Imaging Centre, School of Physics and Astronomy, University of Nottingham, University Park, Nottingham NG7 2RD, UK. ²QuSpin Inc., 331 South 104th Street, Suite 130, Louisville, Colorado 80027, USA. ³Wellcome Centre for Human Neuroimaging, UCL Institute of Neurology, University College London, 12 Queen Square, London WC1N 3BG, UK. ⁴Institute of Cognitive Neuroscience, University College London, 17-19 Queen Square, London WC1N 3AZ, UK. ⁵Centre for Human Brain Health, School of Psychology, University of Birmingham, Edgbaston, Birmingham B15 2TT, UK. ⁶Sobell Department for Motor Neuroscience and Movement Disorders, UCL Institute of Neurology, University College London, Queen Square House, Queen Square, London WC1N 3BG, UK.

*These authors contributed equally to this work.

§These authors jointly supervised this work.

An MEG system with no cryogen

Optically pumped magnetometer (OPM)

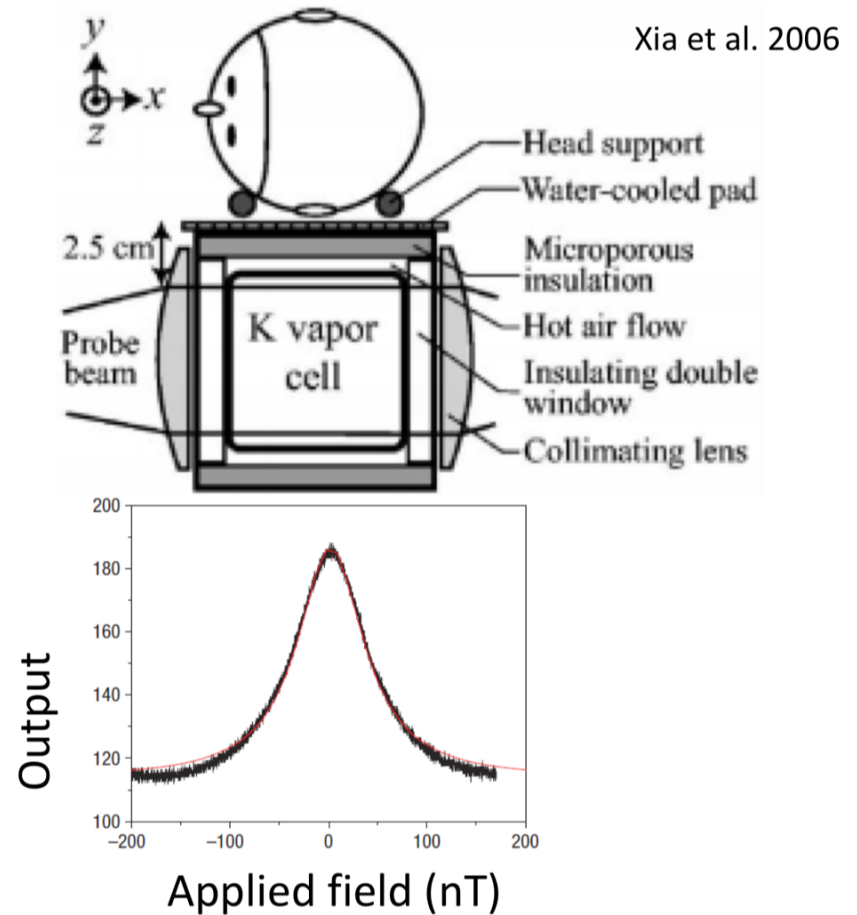
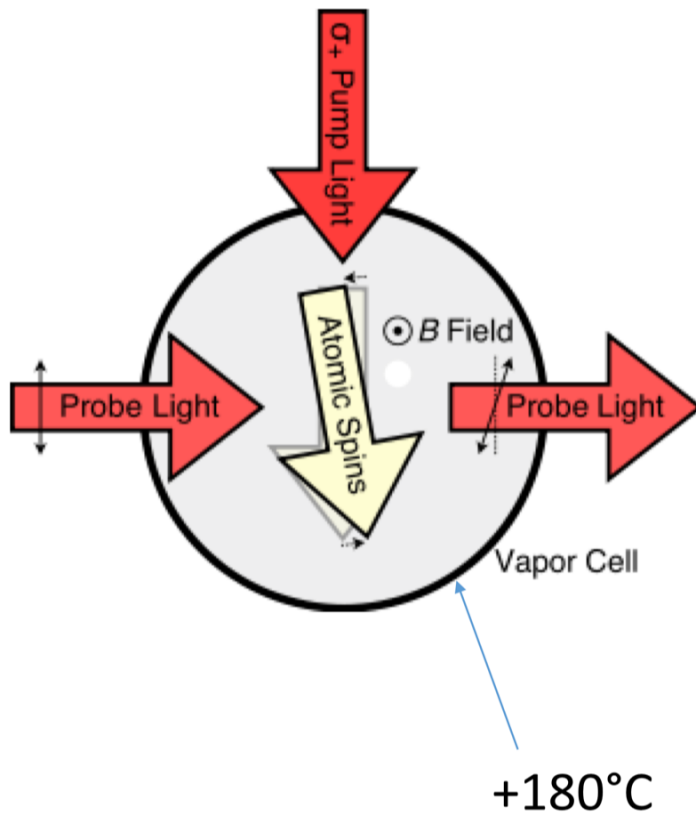

Boto E, Meyer SS, Shah V, Alem O, Knappe S, Kruger P, Fromhold TM, Lim M, Glover PM, Morris PG, Bowtell R, Barnes GR, Brookes MJ.

A new generation of magnetoencephalography:
Room temperature measurements using optically-pumped magnetometers.

Neuroimage. 2017 Apr 1;149:404-414. doi:
10.1016/j.neuroimage.2017.01.034.

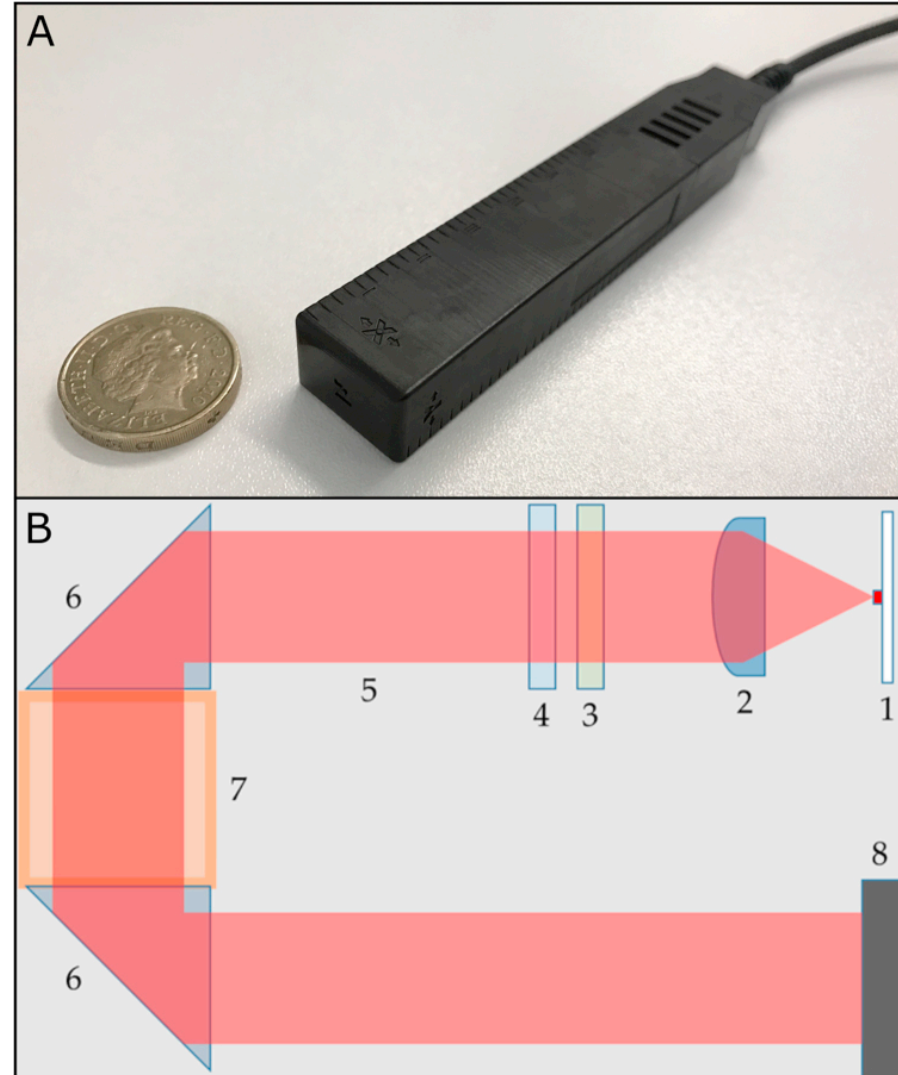

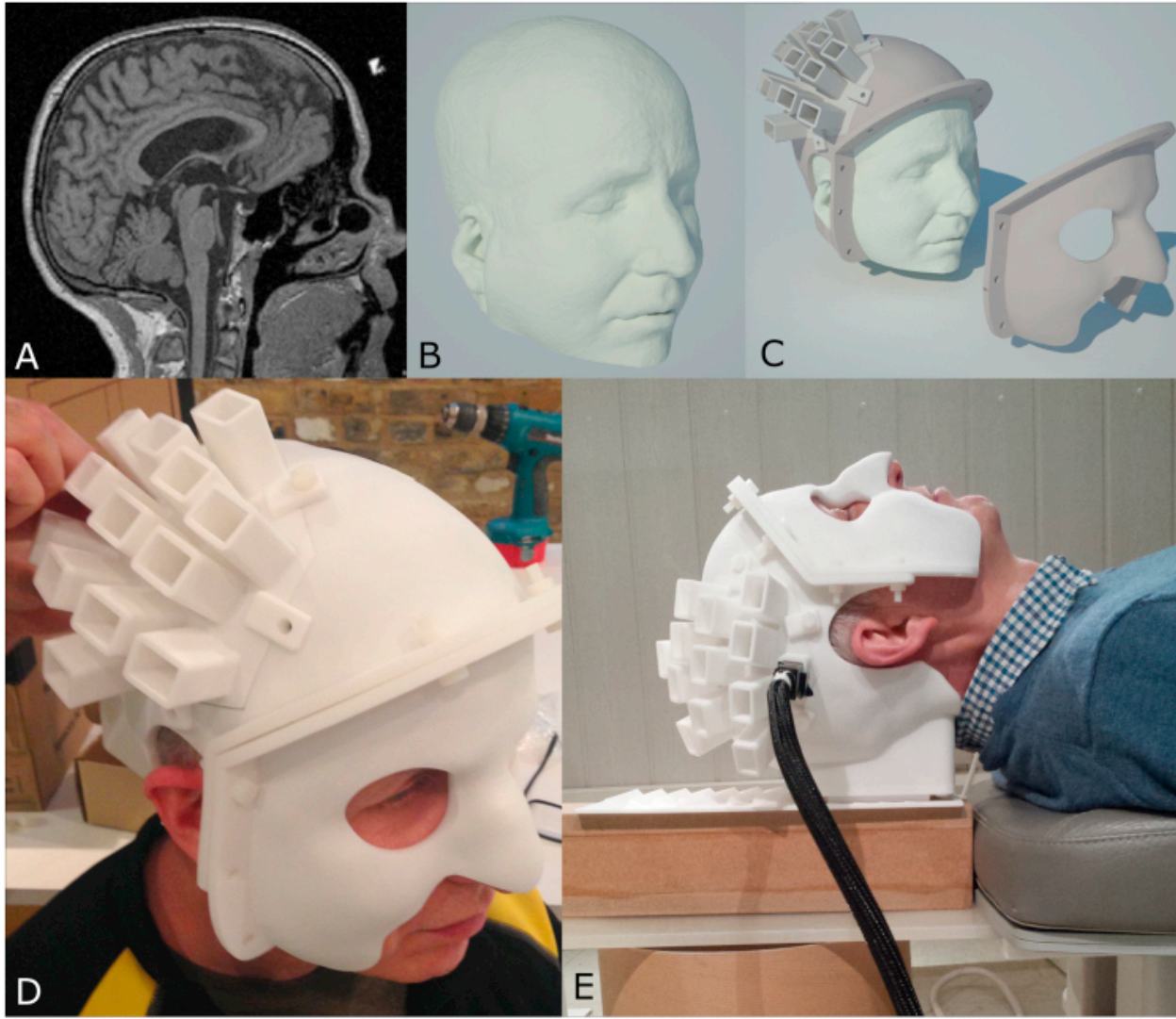

Talk outline

What kind of signals are generated in the brain

How do we record those signals

Analyzing those signals with FieldTrip

Background on the FieldTrip toolbox

M/EEG signal characteristics considered during analysis

timecourse of activity

-> ERP

spectral characteristics

-> power spectrum

temporal changes in power

-> time-frequency response (TFR)

spatial distribution of activity over the head

-> source reconstruction

Evoked activity

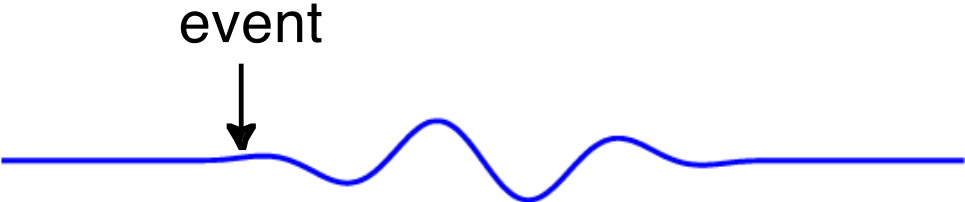

Evoked activity

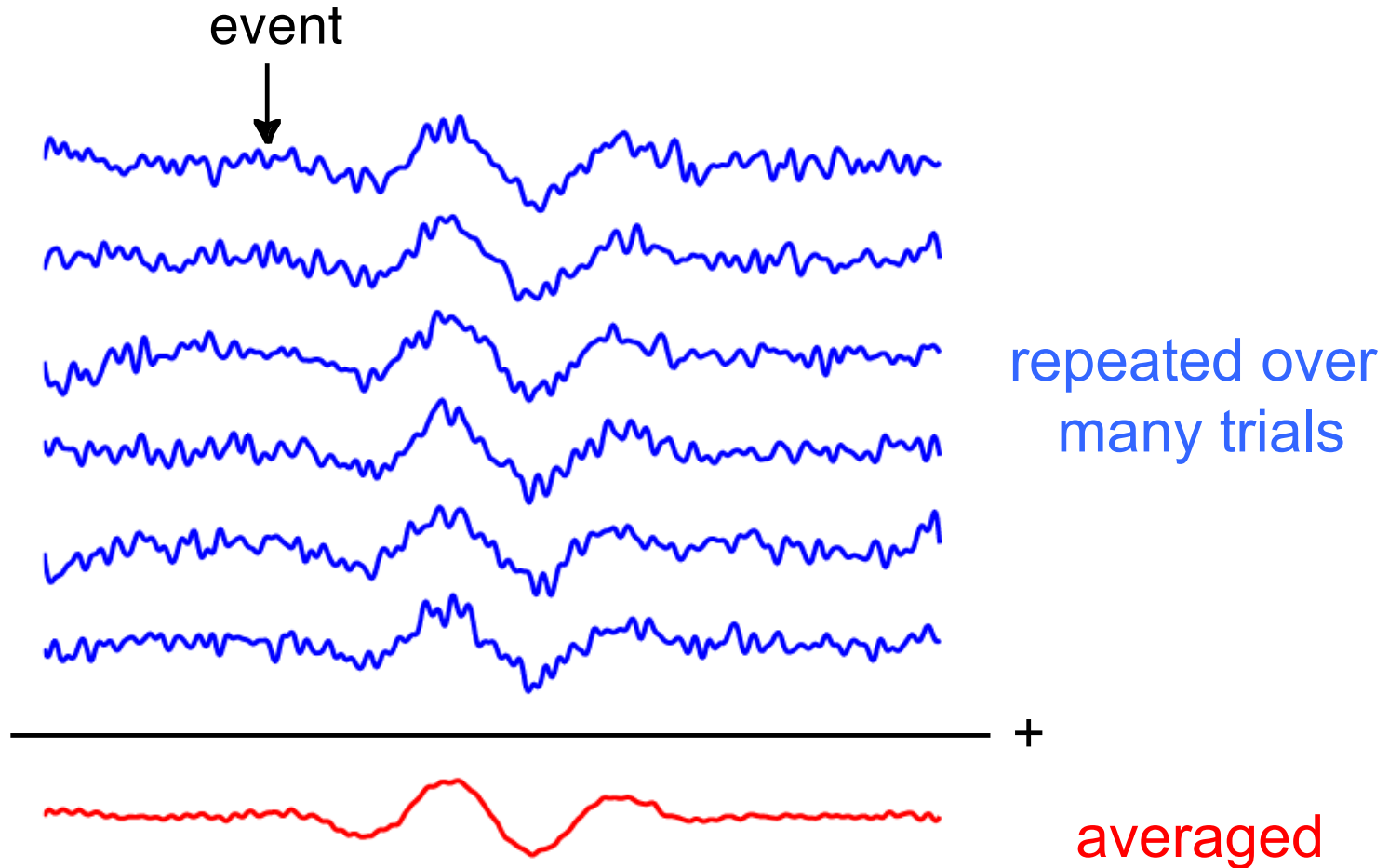

Induced activity

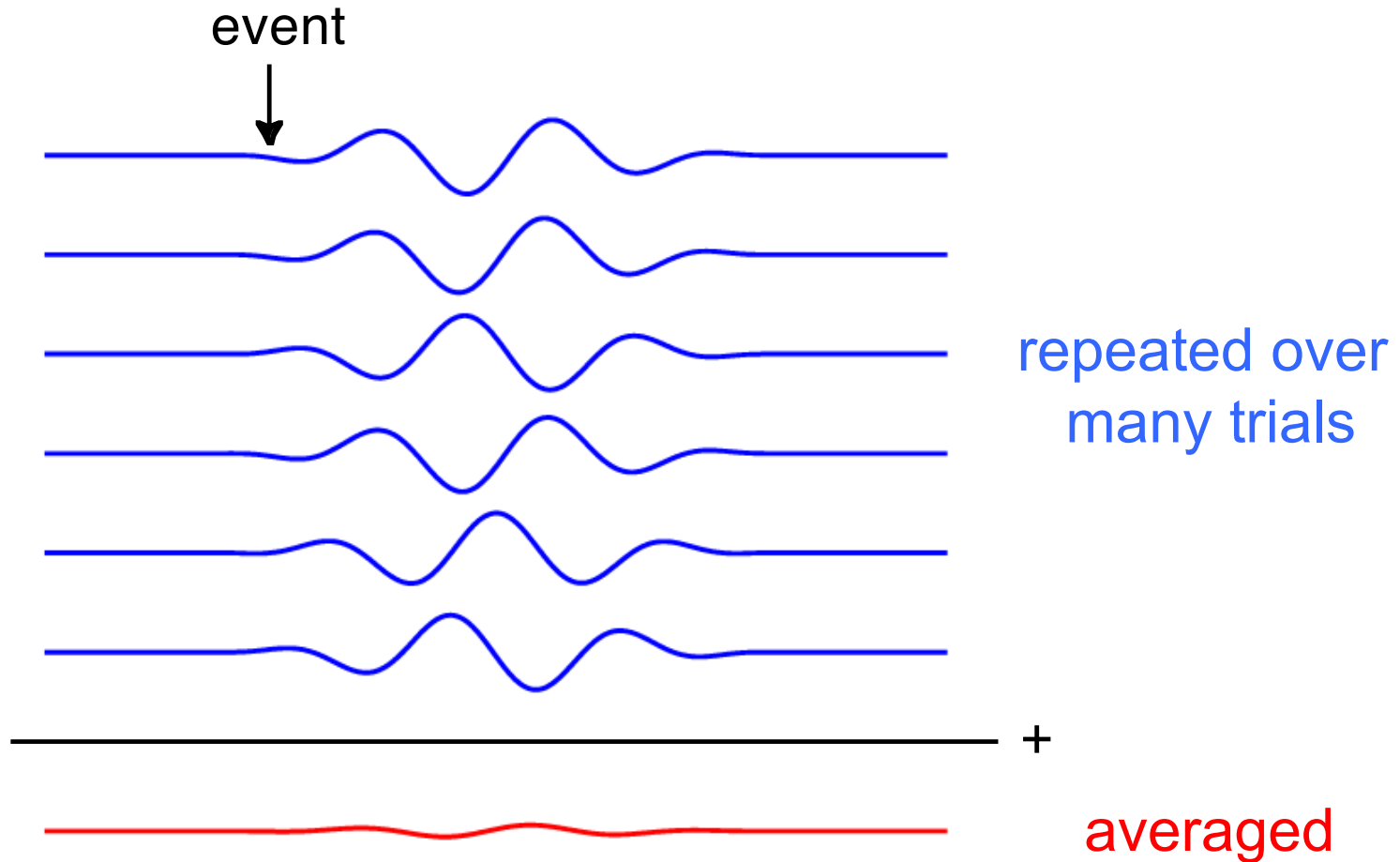

Superposition of source activity

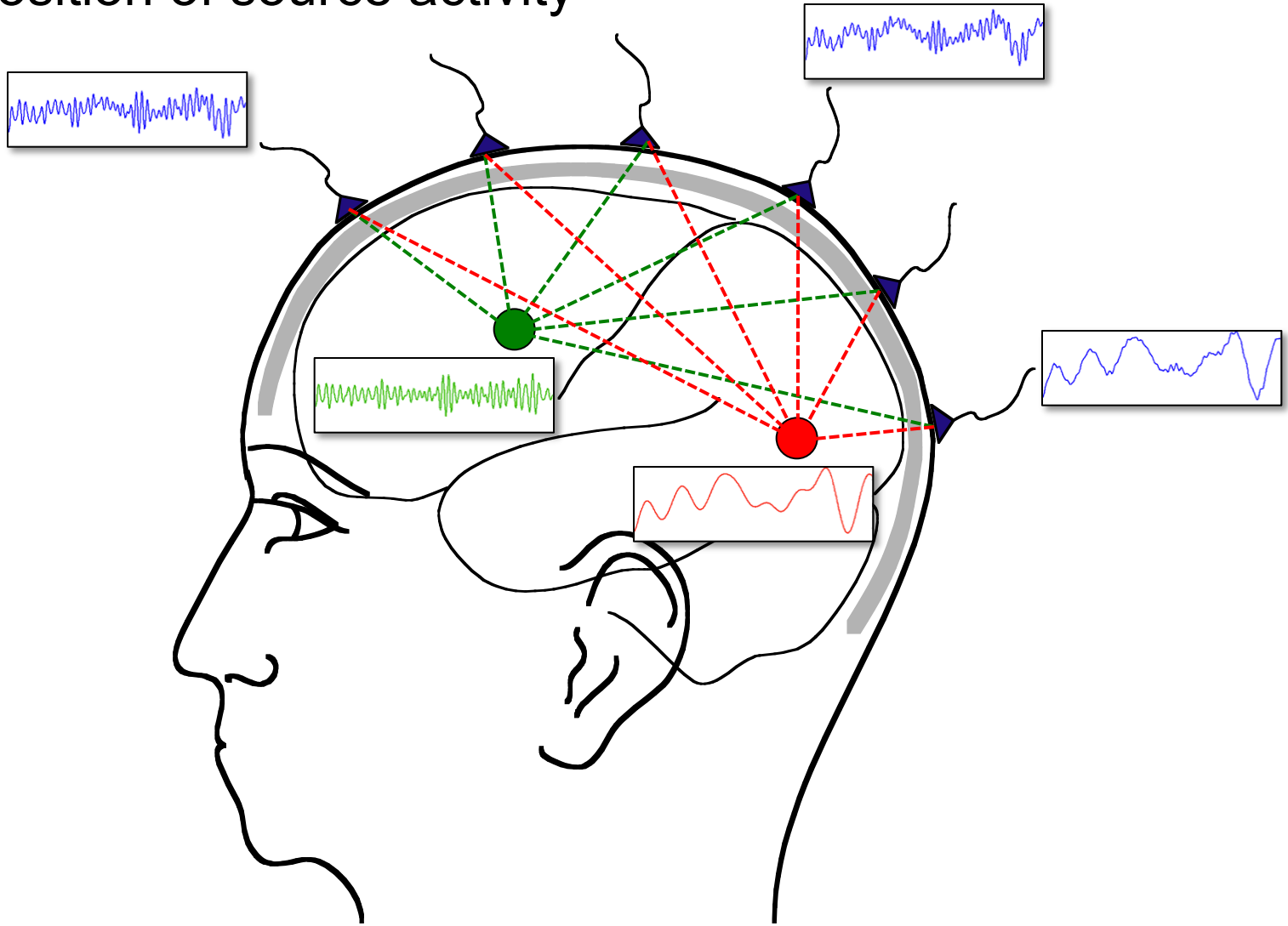

Separating activity of sources

Use the temporal aspects of the data
at the channel level

- ERF latencies

- ERF difference waves

- Filtering the time-series

- Spectral decomposition

Use the spatial aspects of the data

- Volume conduction model of head

- Estimate source model parameters

Talk outline

What kind of signals are generated in the brain

How do we record those signals

Analyzing those signals with FieldTrip

Background on the FieldTrip toolbox

Some FieldTrip basics

```
dataout = functionname(cfg, datain, ...)
```

```
functionname(  
dataout = func
```



the “cfg” argument is a configuration structure, e.g.

```
cfg.channel = {'C3', 'C4', 'F3', 'F4'}
```

```
cfg.foilim = [1 70]
```

FieldTrip v.s. default Matlab

```
dataout = functionname(cfg, datain, ...)
```

```
cfg.key1 = value1  
cfg.key2 = value2
```

```
dataout = functionname(datain, 'key1', 'value1', ...)
```

Using functions in an analysis protocol

ft_preprocessing

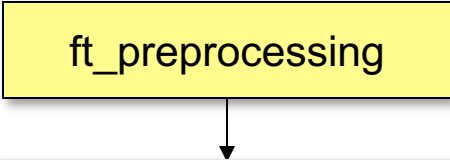

FT_PREPROCESSING reads MEG and/or EEG data according to user-specified trials and applies several user-specified preprocessing steps to the signals.

Use as

```
[data] = ft_preprocessing(cfg)
```

or

```
[data] = ft_preprocessing(cfg, data)
```

The first input argument "cfg" is the configuration structure, which contains all details for the dataset filenames, trials and the preprocessing options. You can only do preprocessing after defining the segments of data to be read from the file (i.e. the trials), which is for example done based on the occurrence of a trigger in the data.

...

Using functions in an analysis protocol

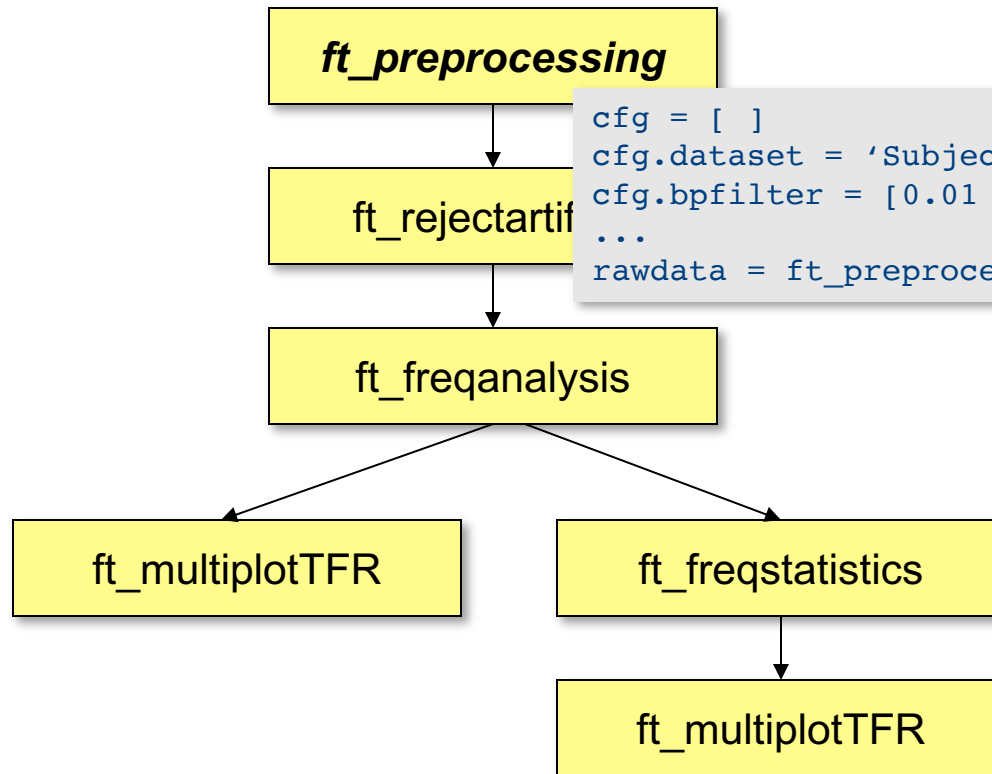

```
cfg = [ ]  
cfg.dataset = 'Subject01.ds'  
cfg.bpfilter = [0.01 150]  
...  
rawdata = ft_preprocessing(cfg)
```

Using functions in an analysis protocol

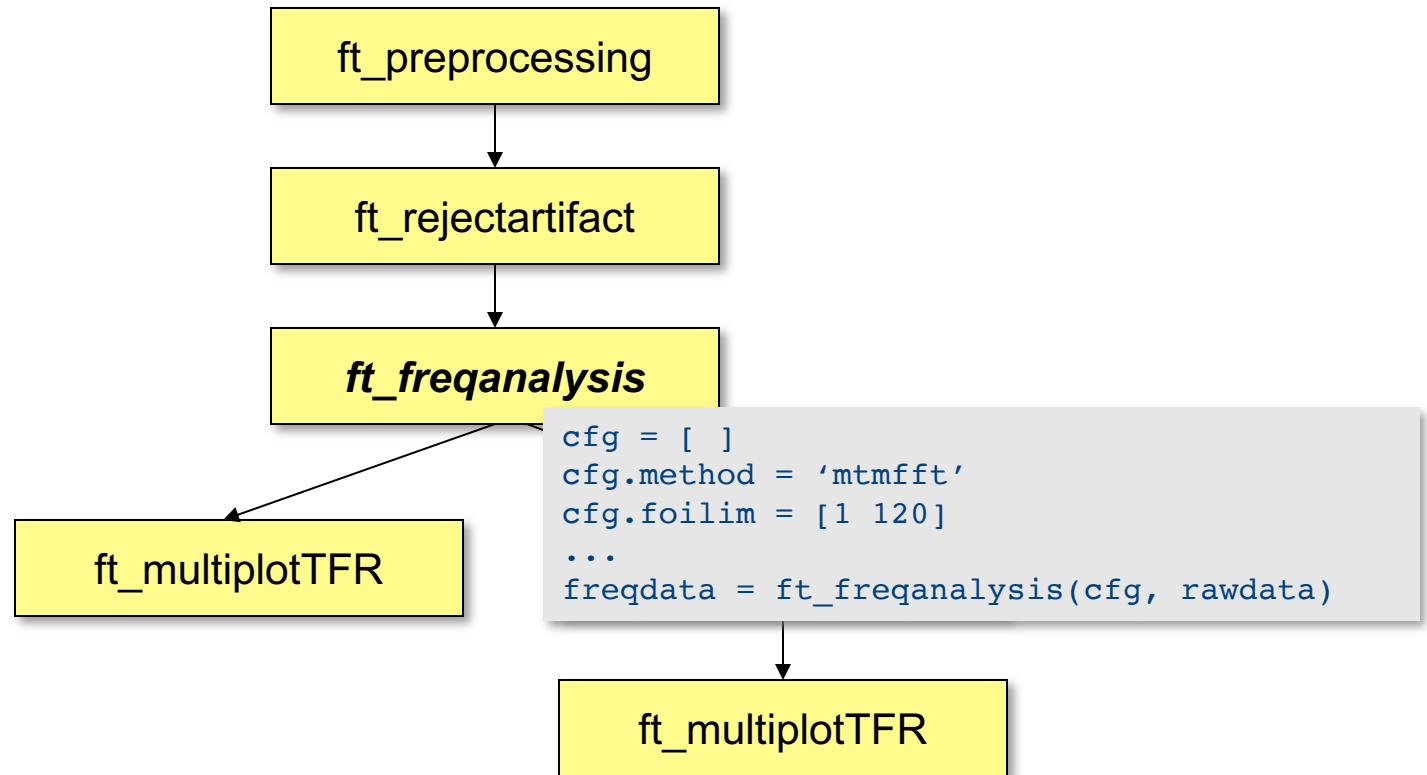

Raw data structure

```
rawData =  
    label: {151x1 cell}  
    trial: {1x80 cell}  
    time: {1x80 cell}  
fsample: 300  
    hdr: [1x1 struct]  
    cfg: [1x1 struct]
```

Event related response

```
timelockData =  
    label: {151x1 cell}  
    avg: [151x900 double]  
    var: [151x900 double]  
    time: [1x900 double]  
    dimord: 'chan_time'  
    cfg: [1x1 struct]
```

Keeping track of your analysis

FieldTrip analysis pipeline, Tue 12-Apr-2016 16:30:38

file:///Users/roboos/Desktop/ERF_Stat_Letter_FacevsLetter.html

FieldTrip analysis pipeline, Tue 12-Apr-2016 16:30:38

```
graph TD; P1[ft_preprocessing] --> A[ft_appenddata]; P2[ft_preprocessing] --> A; P3[ft_preprocessing] --> A; P4[ft_preprocessing] --> A; A --> R1[ft_rejectvisual]; R1 --> R2[ft_rejectvisual]; R2 --> R3[ft_redefintrial]; R3 --> R4[ft_rejectartifact]; R4 --> R5[ft_componentanalysis]; R5 --> R6[ft_rejectcomponent]; R6 --> R7[ft_preprocessing]; R7 --> R8[ft_timelockanalysis]; R7 --> R9[ft_timelockanalysis]; R8 --> R10[ft_timelockstatistics]; R9 --> R10;
```

ft_preprocessing

User-specified configuration

```
cfg.dataset = '/home/fanny/Desktop/MEG_Emo_all/practi...
cfg.trialfun = 'ft_trialfun_general';
cfg.trialdef.eventtype = 'STI101';
cfg.trialdef.eventvalue = [30 31 10 130 131 110];
cfg.trialdef.prestim = 0.7;
cfg.trialdef.poststim = 1.2;
cfg.callinfo.usercfg.dataset = '/home/fanny/Desktop/MEG_Emo_all/practi...
cfg.callinfo.usercfg.trialf... = 'ft_trialfun_general';
cfg.callinfo.usercfg.triald... = 'STI101';
cfg.callinfo.usercfg.triald... = [30 31 10 130 131 110];
cfg.callinfo.usercfg.triald... = 0.7;
cfg.callinfo.usercfg.triald... = 1.2;
cfg.callinfo.usercfg.trackc... = 'off';
cfg.callinfo.usercfg.checkc... = 'loose';
cfg.callinfo.usercfg.checks... = 100000;
cfg.callinfo.usercfg.showca... = 'yes';
cfg.callinfo.usercfg.debug = 'no';
cfg.callinfo.usercfg.output... = 'overwrite';
cfg.callinfo.usercfg.trackc... = 'yes';
cfg.callinfo.usercfg.trackd... = 'no';
```

Pipeline HTML generated by roboos on Tue 12-Apr-2016 16:30:38.
Estimated total pipeline processing time: 17.1 minutes.

Example use in scripts

```
cfg = []
cfg.dataset = 'Subject01.ds'
cfg.bpfiler = [0.01 150]
...
rawdata = ft_preprocessing(cfg)
```

```
cfg = []
cfg.method = 'mtmfft'
cfg.foylim = [1 120]
...
freqdata = ft_freqanalysis(cfg, rawdata)
```

```
cfg = []
cfg.method = 'montecarlo'
cfg.statistic = 'indepsamplesT'
cfg.design = [1 2 1 2 2 1 2 1 1 2 ... ]
...
freqstat = ft_freqstatistics(cfg, freqdata)
```

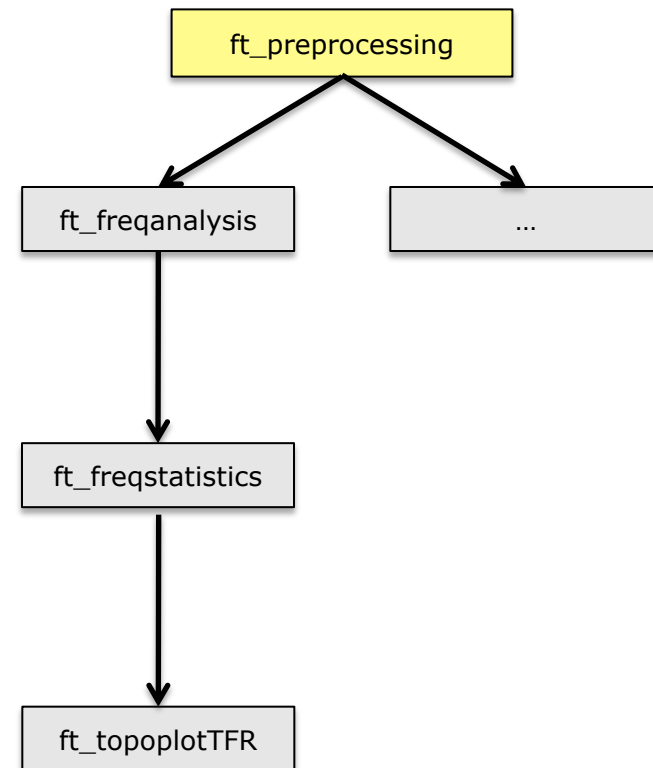

Example use in scripts

```
cfg = []  
cfg.dataset = 'Subject01.ds'  
cfg.bpfiler = [0.01 150]  
...  
rawdata = ft_preprocessing(cfg)
```

```
cfg = []  
cfg.method = 'mtmfft'  
cfg.foylim = [1 120]  
...  
freqdata = ft_freqanalysis(cfg, rawdata)
```

```
cfg = []  
cfg.method = 'montecarlo'  
cfg.statistic = 'indepsamplesT'  
cfg.design = [1 2 1 2 2 1 2 1 1 2 ... ]  
...  
freqstat = ft_freqstatistics(cfg, freqdata)
```

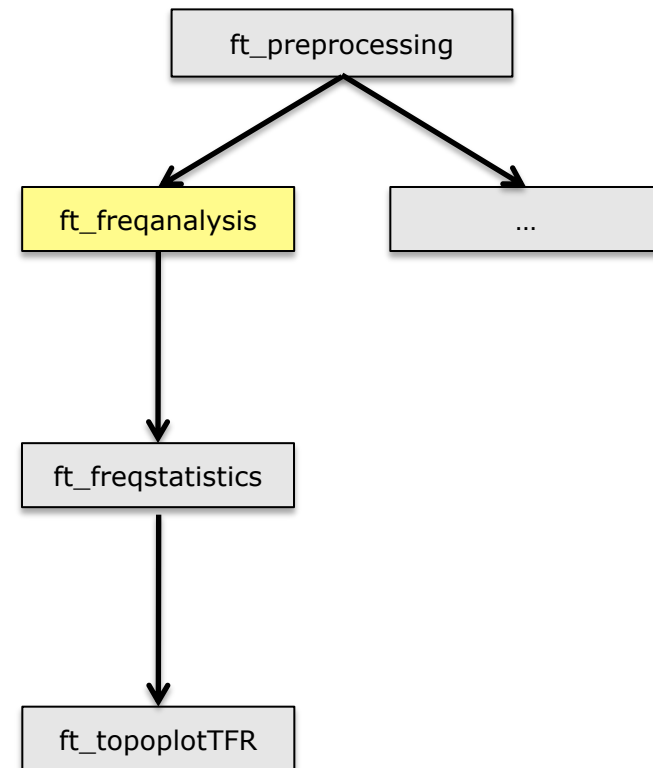

Example use in scripts

```
cfg = []  
cfg.dataset = 'Subject01.ds'  
cfg.bpfiler = [0.01 150]  
...  
rawdata = ft_preprocessing(cfg)
```

```
cfg = []  
cfg.method = 'mtmfft'  
cfg.foylim = [1 120]  
...  
freqdata = ft_freqanalysis(cfg, rawdata)
```

```
cfg = []  
cfg.method = 'montecarlo'  
cfg.statistic = 'indepsamplesT'  
cfg.design = [1 2 1 2 2 1 2 1 1 2 ... ]  
...  
freqstat = ft_freqstatistics(cfg, freqdata)
```

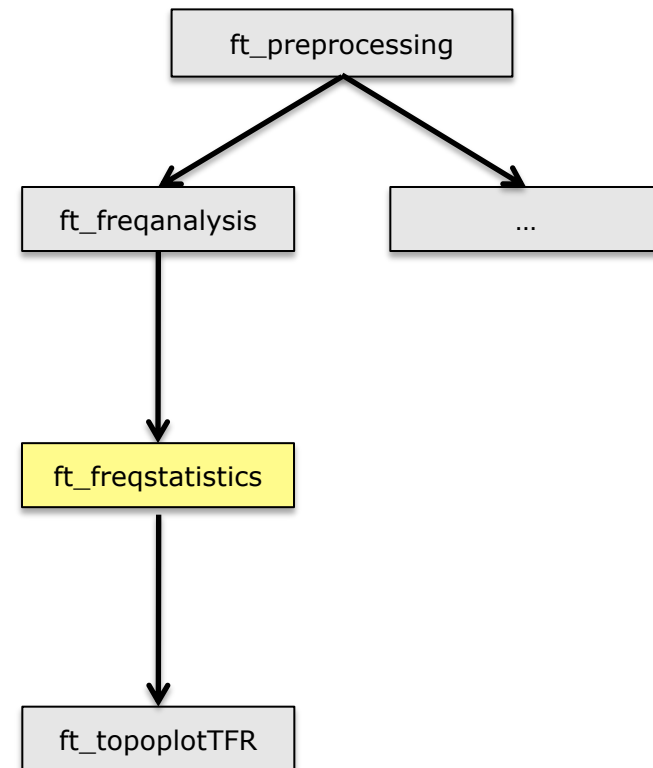

Example use in scripts

```
cfg = []  
cfg.dataset = 'Subject01.ds'  
cfg.bpfiler = [0.01 150]  
...  
rawdata = ft_preprocessing(cfg)
```

```
cfg = []  
cfg.method = 'mtmfft'  
cfg.foylim = [1 120]  
...  
freqdata = ft_freqanalysis(cfg, rawdata)
```

```
cfg = []  
cfg.method = 'montecarlo'  
cfg.statistic = 'indepsamplesT'  
cfg.design = [1 2 1 2 2 1 2 1 1 2 ... ]  
...  
freqstat = ft_freqstatistics(cfg, freqdata)
```

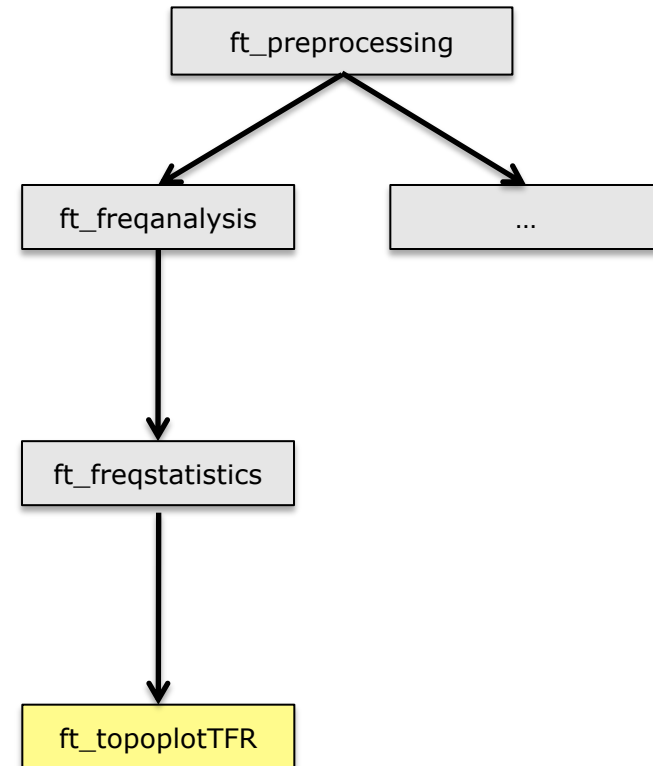

Example use in scripts

```
cfg = []  
cfg.dataset = 'Subject01.ds'  
cfg.bpfiler = [0.01 150]  
...  
rawdata = ft_preprocessing(cfg)
```

```
cfg = []  
cfg.method = 'mtmfft'  
cfg.foylim = [1 120]  
...  
freqdata = ft_freqanalysis(cfg, rawdata)
```

```
cfg = []  
cfg.method = 'montecarlo'  
cfg.statistic = 'indepsamplesT'  
cfg.design = [1 2 1 2 2 1 2 1 1 2 ... ]  
...  
freqstat = ft_freqstatistics(cfg, freqdata)
```

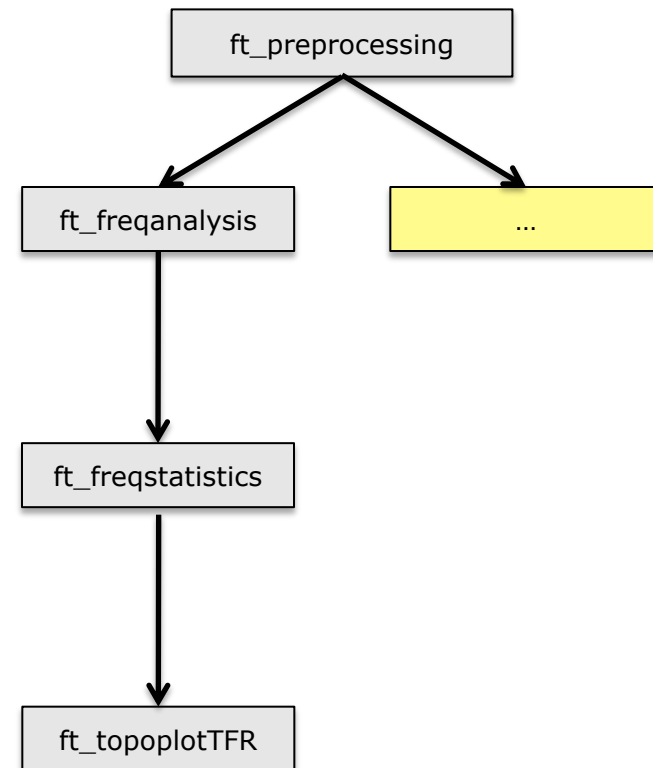

Example use in scripts

```
subj = {'S01.ds', 'S02.ds', ...}
trig = [1 3 7 9]

for s=1:nsubj
for c=1:ncond

    cfg = []
    cfg.dataset = subj{s}
    cfg.trigger = trig(c)
    rawdata{s,c} = ft_preprocessing(cfg)

    cfg = []
    cfg.method = 'mtmfft'
    cfg.foilim = [1 120]
    freqdata{s,c} = ft_freqanalysis(cfg, rawdata{s,c})

end
end
```

Example use in scripts

```
subj = {'S01.ds', 'S02.ds', ...}
trig = [1 3 7 9]

for s=1:nsubj
for c=1:ncond

    cfg = []
    cfg.dataset = subj{s}
    cfg.trigger = trig(c)
    rawdata = ft_preprocessing(cfg)

    filename = sprintf('raw%s_%d.mat', subj{s}, trig(c));
    save(filename, 'rawdata')

end
end
```

Example use in distributed computing

```
subj = {'S01.ds', 'S02.ds', ...}
trig = [1 3 7 9]

for s=1:nsubj
for c=1:ncond

    cfgA{s,c} = []
    cfgA{s,c}.dataset      = subj{s}
    cfgA{s,c}.trigger      = trig(c)
    cfgA{s,c}.outputfile  = sprintf('raw%s_%d.mat', subj{s}, trig(c))

    cfgB{s,c} = []
    cfgB{s,c}.dataset      = subj{s}
    cfgB{s,c}.trigger      = trig(c)
    cfgB{s,c}.inputfile    = sprintf('raw%s_%d.mat', subj{s}, trig(c));
    cfgB{s,c}.outputfile  = sprintf('freq%s_%d.mat', subj{s}, trig(c));

end
end

dfeval(@ft_preprocessing, cfgA)
dfeval(@ft_freqanalysis,  cfgB)
```

Example use in distributed computing

```
subj = {'S01.ds', 'S02.ds', ...}
trig = [1 3 7 9]

for s=1:nsubj
for c=1:ncond

    cfgA{s,c} = []
    cfgA{s,c}.dataset      = subj{s}
    cfgA{s,c}.trigger      = trig(c)
    cfgA{s,c}.outputfile  = sprintf('raw%s_%d.mat', subj{s}, trig(c))

    cfgB{s,c} = []
    cfgB{s,c}.dataset      = subj{s}
    cfgB{s,c}.trigger      = trig(c)
    cfgB{s,c}.inputfile    = sprintf('raw%s_%d.mat', subj{s}, trig(c));
    cfgB{s,c}.outputfile  = sprintf('freq%s_%d.mat', subj{s}, trig(c));

end
end

qsubcellfun(@ft_preprocessing, cfgA)
qsubcellfun(@ft_freqanalysis,  cfgB)
```

FieldTrip is a toolbox

the data and the separate functions are in
your hands

the scripts depend on the data properties,
your computer and on your programming
skills and style

scripts correspond to analysis protocols

- scripts can be reviewed by supervisors

- scripts are often shared with colleagues

- scripts can be published/released

One-to-one mapping between analysis steps and toolbox functions

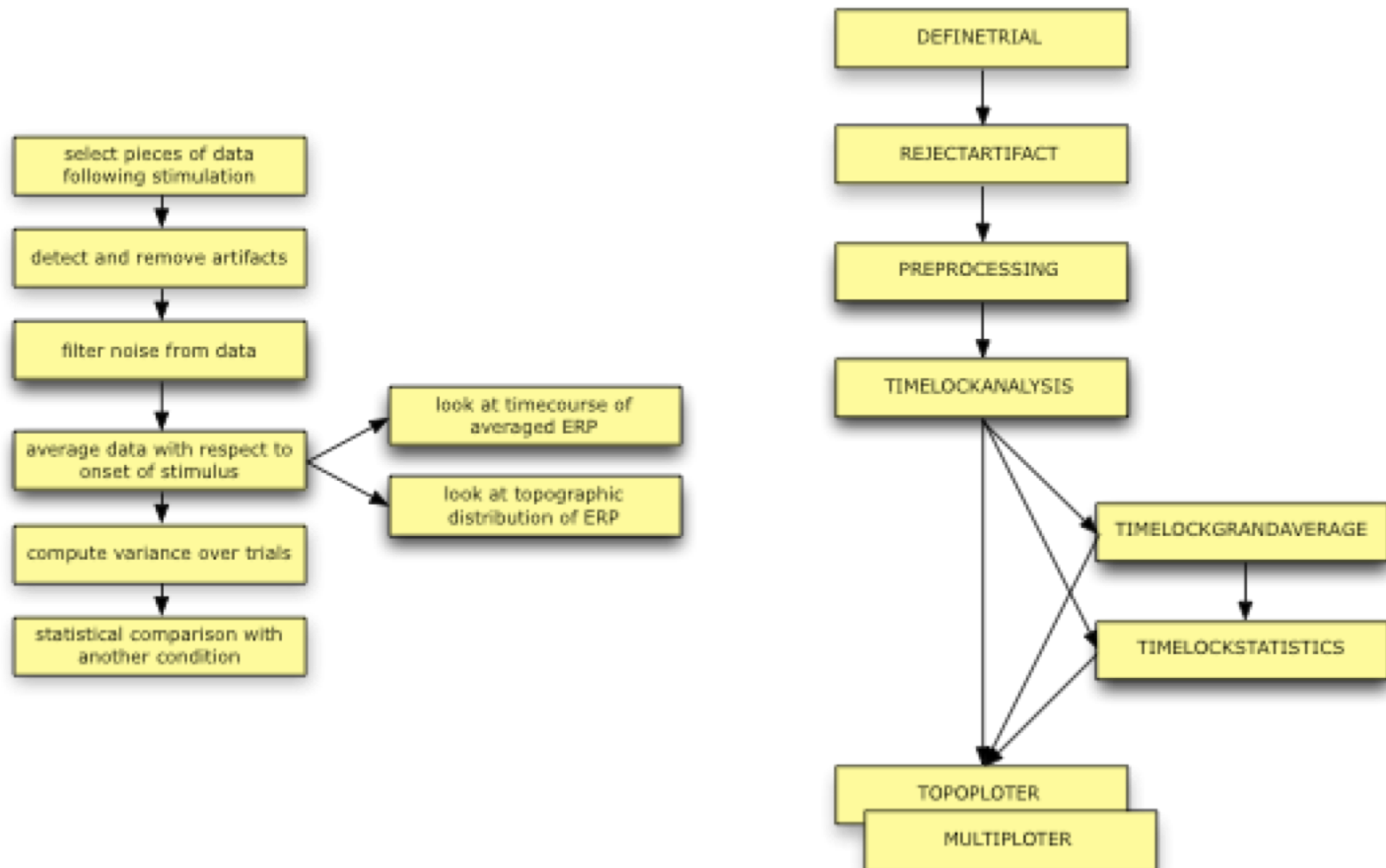

Overview of main functions

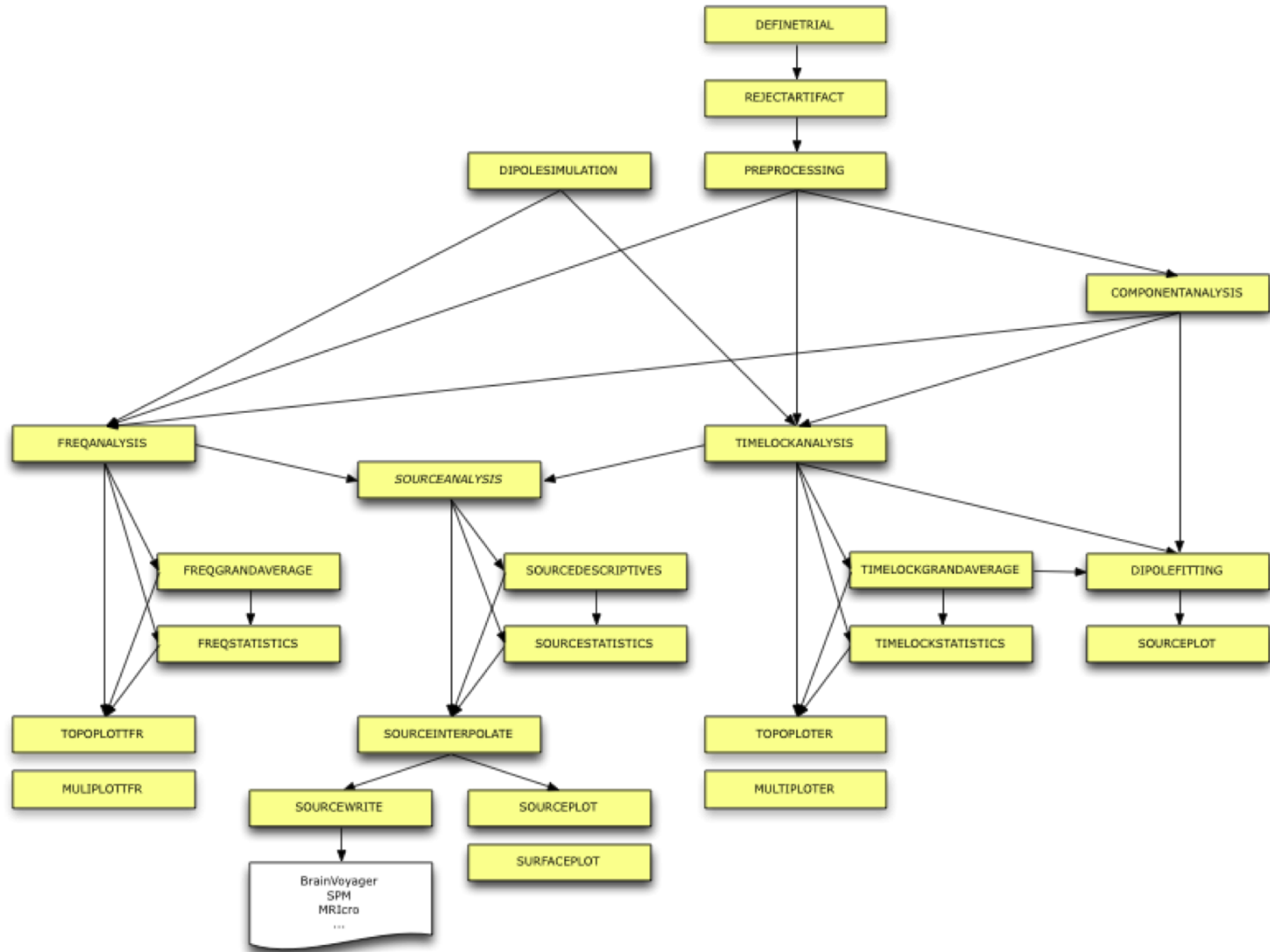

Finding your way around in the FieldTrip toolbox

Matlab

help functionname

edit functionname

Website

<http://www.fieldtriptoolbox.org>

Email discussion list

Expertise in your local group

Talk outline

What kind of signals are generated in the brain

How do we record those signals

Analyzing those signals with FieldTrip

Background on the FieldTrip toolbox

Who is the audience?

experimental neuroscientists

no graphical user interface

more dedicated and ambitious researchers

developers of other software packages

SPM

EEGLAB

BESA

BCI2000

developers of analysis tools and methods

SIMBIO

OpenMEEG

FieldTrip toolbox structure - at a glance

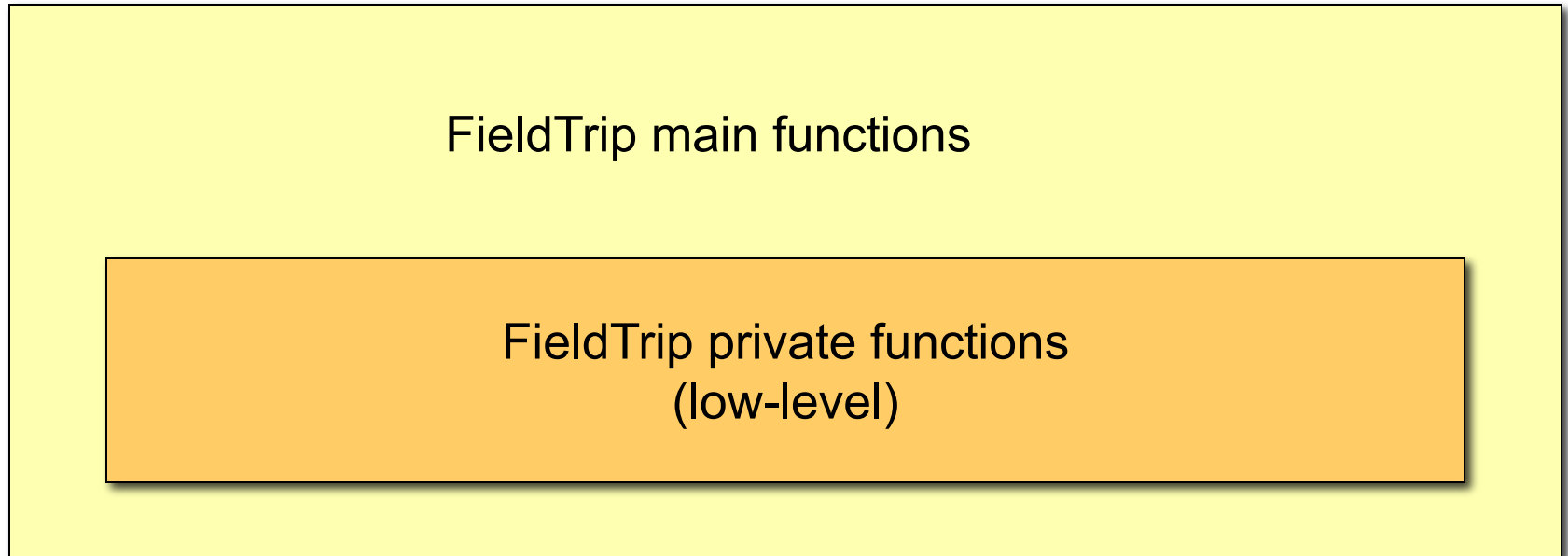
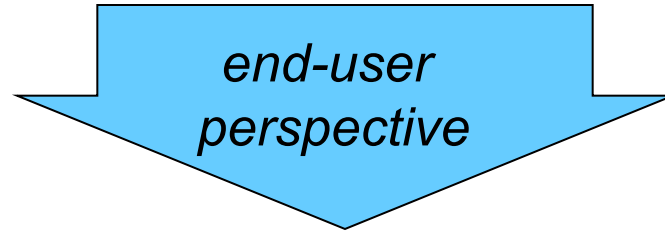

FieldTrip toolbox structure - a closer look

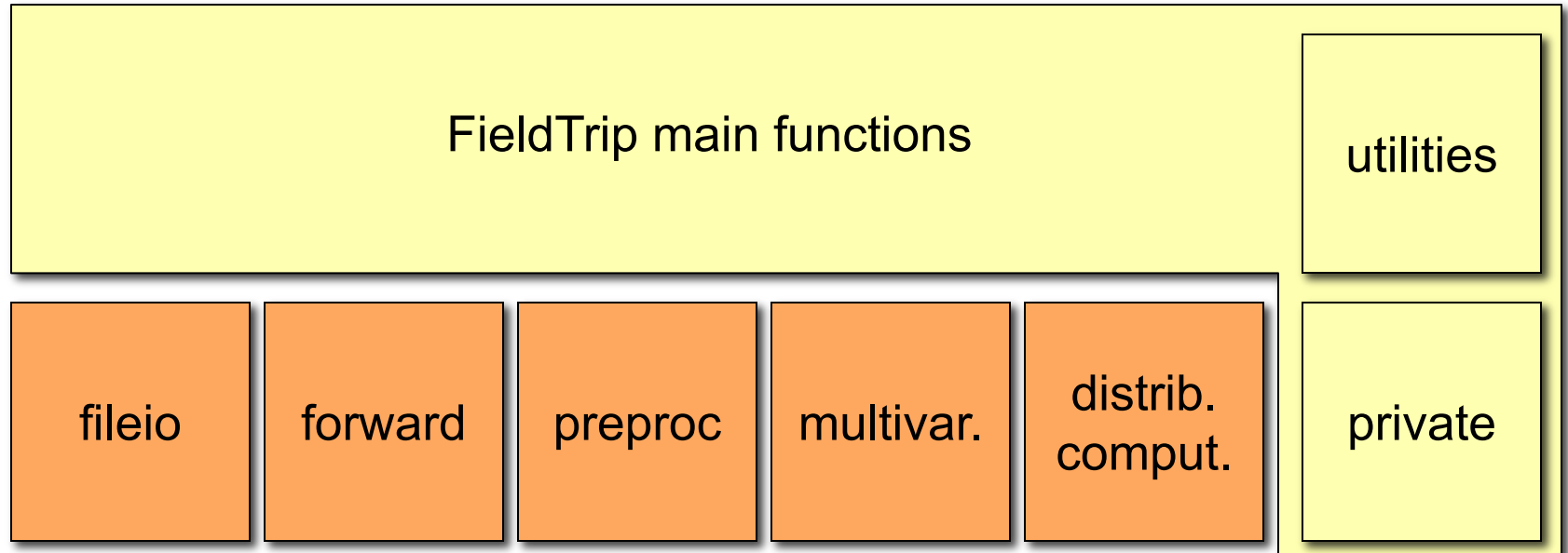
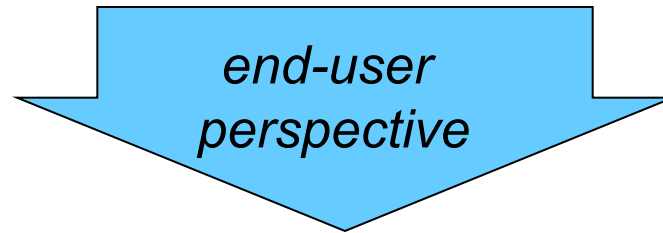

FieldTrip toolbox structure - a closer look

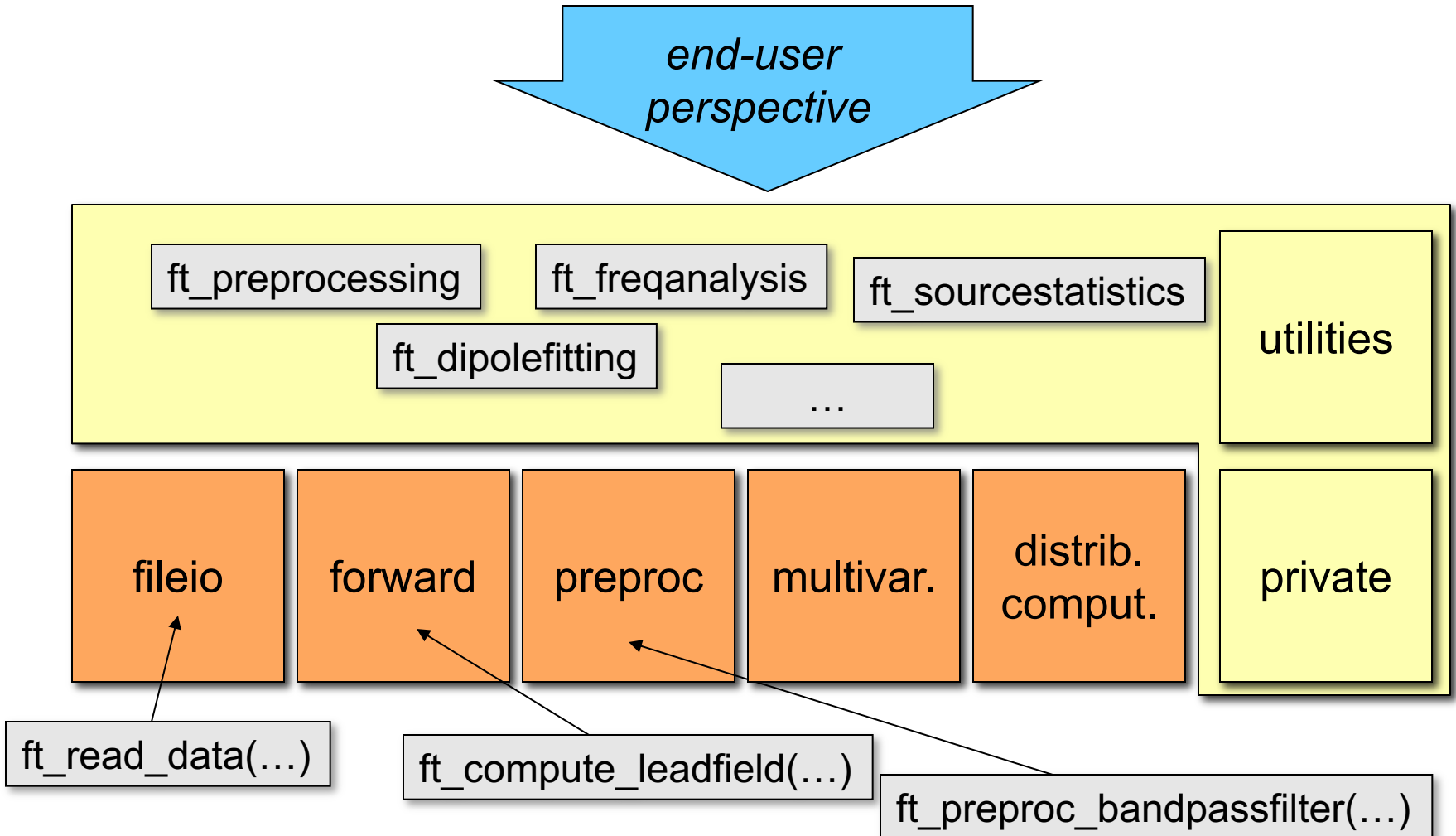

Summary

What kind of signals are generated in the brain

How do we record those signals

Analyzing those signals with FieldTrip

Background on the FieldTrip project

After coffee: lab demonstration

After lunch: hands-on

Selecting segments of data

Reading and preprocessing

Averaging

Plotting

